

Installation instructions (original)

Transportation | Assembly | Operation | Maintenance



Product line:	aircoolers R134a, R404A, ...
Series description:	Güntner cubic Agri air coolers (fruit and vegetable coolers)
Series:	GACA RX

www.guentner.de

Contents

1	Important basic information.....	5
1.1	Safety instructions.....	5
1.1.1	Observing operating instructions.....	5
1.2	Importance of the EN 378 series of standards – refrigeration systems and heat pumps – safety-related and environmental requirements.....	5
1.3	Responsibilities.....	5
1.3.1	Manufacturer's responsibilities.....	5
1.3.2	Responsibilities of the system's installer.....	6
1.3.3	Owner or operator responsibilities.....	6
1.4	Legal notes.....	7
1.5	Operating instructions.....	7
1.5.1	Scope.....	7
1.5.2	Set-up and other applicable documents.....	7
1.6	Conventions.....	8
1.6.1	Typographical conventions.....	8
1.6.2	List of abbreviations.....	8
1.7	Conventions for safety signs and notices.....	9
1.7.1	General safety signs and their meaning in these operating instructions.....	9
1.7.2	Warning symbols and their meaning in these operating instructions.....	9
1.7.3	Prohibitory signs and their meaning in these operating instructions.....	10
1.7.4	Mandatory signs and their meaning in these operating instructions.....	10
2	Safety.....	12
2.1	Labelling on the unit:.....	12
2.1.1	Safety signs on the unit.....	13
2.1.2	Other signs and notes on the unit.....	15
2.2	Basic safety notices.....	17
2.2.1	How to act in an emergency.....	17
2.2.2	Personnel, care requirements.....	17
2.3	Proper intended use.....	18
2.3.1	Proper intended use.....	18
2.3.2	Operating conditions.....	18
2.3.3	Improper use.....	19
2.4	Mechanical residual hazards.....	20
2.4.1	Fins, sharp unit corners and edges.....	20
2.4.2	Flap down drip tray.....	20
2.4.3	Fans.....	21

2.4.4	Hinged side plates.....	21
2.5	Electrical residual hazards.....	22
2.6	Thermal residual hazards.....	22
2.6.1	Danger of burns.....	22
2.6.2	Frostbite hazard.....	23
2.6.3	Overheating.....	23
2.7	Residual hazards due to CFC/HFC refrigerants.....	23
2.8	Residual hazards caused by vibrations.....	24
2.9	Residual hazards caused by pressurised parts.....	25
2.10	Residual hazards caused by defective installation.....	25
2.11	Residual hazards with break during operation.....	26
2.12	Residual hazards caused by escaping objects or liquids.....	27
2.13	Residual hazards with disposal.....	27
3	Technical data.....	29
3.1	heat exchanger (typical values).....	29
3.2	Fans.....	29
4	Set-up and function.....	31
5	Fan motor.....	32
6	Transportation and storage.....	33
6.1	Safety.....	33
6.2	Transportation and storage.....	33
6.3	Storage before installation.....	34
7	Set-up and start-up.....	35
7.1	Safety.....	35
7.1.1	Safety instructions for set-up and start-up.....	35
7.1.2	System-side safety requirements.....	36
7.1.3	Customer-side safety precautions.....	37
7.2	Requirements at the set-up point.....	38
7.3	Unpacking the unit.....	39
7.4	Installation.....	41
7.4.1	System-side requirements for stress-free installation.....	41
7.4.2	Mounting the unit.....	42
7.5	Notes on connecting the unit.....	42
7.5.1	Connecting the drain line to the drip tray.....	42
7.5.2	Connect the unit to the system.....	43
7.5.3	Unit electrical connection and protection.....	44
7.6	Perform acceptance test.....	44
7.7	Test readiness for operation.....	45
7.8	Putting the unit into operation for the first time.....	45
8	Operation.....	47

8.1	Safety.....	47
8.2	Putting the unit into operation.....	47
8.3	Taking the unit out of operation.....	47
8.4	Shutting the unit down.....	47
8.5	Putting the unit into operation after a shutdown.....	48
8.6	Changing the unit over to another working fluid.....	48
9	Troubleshooting.....	50
9.1	Safety.....	50
9.2	Service.....	50
9.3	Troubleshooting table.....	50
9.4	Dealing with faults.....	51
10	Maintenance.....	52
10.1	Safety.....	52
10.1.1	Before starting all maintenance.....	52
10.1.2	With all maintenance work.....	52
10.1.3	After all maintenance work.....	53
10.2	Inspection and maintenance plan.....	53
10.2.1	Fans.....	53
10.2.2	Unit heat exchanger.....	54
10.3	Maintenance work.....	55
10.3.1	Remove leaks.....	55
10.4	Clean unit.....	55
10.4.1	General.....	55
10.4.2	Removing the drip tray and side cover.....	55
10.4.3	Clean heat exchanger.....	58
10.4.4	Cleaning fans.....	59
10.5	Defrosting the unit.....	60
10.5.1	Notes on defrosting.....	60
10.5.2	Defrost control.....	61
10.5.3	Circulation air defrosting.....	62
10.5.4	Electric defrosting	62
10.5.5	Further notes on defrosting.....	63
11	Plans/diagrams.....	64
11.1	Electrics documentation.....	64
11.1.1	Fan motor connection diagram.....	64

1 Important basic information

1.1 Safety instructions

1.1.1 Observing operating instructions

CAUTION

- ▶ Always keep the operating instructions in the unit's immediate vicinity at all times.
- ▶ Ensure that the operating instructions are accessible to all people that have anything at all to do with the unit at all times.
- ▶ Ensure that the operating instructions are read and understood by all people that have anything at all to do with the unit.

1.2 Importance of the EN 378 series of standards – refrigeration systems and heat pumps – safety-related and environmental requirements

EN 378 deals with safety-related and environmental requirements for designing, constructing, producing, installing, operating, maintaining and disposing of refrigeration systems and cooling equipment.

EN 378 is oriented towards manufacturers, installers and operators of refrigeration systems and cooling equipment (see section 1.2. Responsibilities).

The objective of EN 378 is to restrict the possible hazards of refrigeration systems, cooling equipment and their working fluids (refrigerants and coolants) for people, property and the environment to a minimum.

Insufficient safety measures or non-compliance with safety-relevant regulations can result in:

- Breaks or ruptures on components with the danger of escaping materials (hazards caused by the influence of low temperatures, excess pressure, direct influence of the fluid phase, moving machine parts).
- Escaping working fluid after a break or leak because of defective design, improper operation, insufficient maintenance, repairs, filling and disposal (hazards caused by oxygen deficiency, flammability, frostbite, suffocation, panic)

1.3 Responsibilities

1.3.1 Manufacturer's responsibilities

The notes provided in these operating instructions on maintaining the unit's functional safety, preventing possible hazards when transporting, setting up and installing, start-up and operation, and with maintenance activities (cleaning, servicing and repairing) refer exclusively to the unit.

The manufacturer's responsibilities are documented in the unit's version in acc. with EN 378-2 (design, manufacture and testing).

The materials used in the construction and for soldering and welding are designed to withstand the foreseeable mechanical, thermal and chemical stresses, and are resistant to the working fluids used and to mixtures of such working fluids and the oils used to lubricate refrigeration compressors.

The working fluid-carrying parts of the unit (core tubes, distributor tube and header outlet) are configured so that they remain tight with the foreseeable mechanical, thermal and chemical stresses, and withstand the maximum permissible operating pressure.

Material, wall thickness, tensile strength, corrosive resistance, shaping process and testing are suitable for the working fluid used and withstand the possible pressures and stresses that might occur.

All responsibility for the equipment into which the unit is integrated, are the exclusive responsibility of the people involved in the individual workflows.

1.3.2 Responsibilities of the system's installer

The responsibilities of the system installer are documented in the system's version (design, manufacture and testing – in accordance with EN 378-2).

Component supplier-system installer interfaces :

- In the event of any malfunction, inform Guntner GmbH & Co. KG :
Inform Guntner GmbH & Co. KG immediately if faults occur during the set-up, installation, start-up and operation..

The responsibilities of the system installer in particular include:

- Planning and preparing emergency measures:
To avoid consequential damage caused by operational disruptions, a warning system which immediately signals all faults must be provided on-site. Prepare emergency measures that prevent consequential damage for people and property should faults occur.
- Specify checking and maintenance intervals:
The system must be configured and equipped with all required equipment for maintenance and sufficient servicing and testing in accordance with EN 378-4.

When the unit is integrated into the refrigeration system , the working fluid and version must not deviate from the order-related information specified in the order-related documents.

The installer of the system must refer to the requirement for sufficient instruction of the operating and supervision staff when operating and maintaining the equipment .

It is recommended that the future customer staff – if possible – be present during the set-up and installation, for tightness tests and cleaning, while the system is being filled with working fluid and for the adjustment of the equipment .

1.3.3 Owner or operator responsibilities

The owner or operator responsibilities are documented in the operation, maintenance, servicing and recovery of the system in accordance with EN 378-4.

The owner or operator must ensure that the proper people are sufficiently trained and qualified for operating, monitoring and servicing the system .

The operating personnel for the system must have sufficient knowledge and experience with regard to the mode of operation, operation and daily monitoring of this system .

Before starting up the system, the owner or operator must ensure that the operating personnel are sufficiently instructed about the system's documentation (which is part of the operating instructions) on the set-up, monitoring, mode of operation and servicing of the system and the safety measures to be observed, and with regard to the properties and handling of the working fluid to be used.

The owner or operator must ensure that when operating, monitoring and maintaining the system the working fluid and version must not deviate from the details specified in the order-related documents.

Planning and preparing emergency measures: To avoid consequential damage caused by operational disruptions, a warning system must be installed on the customer's premises. Prepare emergency measures that prevent consequential damage for people and property should faults occur.

Responsibility remains with the owner or operator of the system, if the system are used by anybody else, unless there is a contrary agreement on sharing responsibility.

1.4 Legal notes

Warranty claim expires as follows:

- With faults and damages that can be attributed to non-compliance with the specifications of these operating instructions.
- With complaints that can be attributed to use of spare parts other than the original spare parts specified in the order-related offer documents.
- With changes to the unit (working fluid, version, function, operating parameters) vis-a-vis the order-related information specified in the order-related offer documents without the manufacturer's prior consent.

The operating instructions may not be reproduced electronically or mechanically, circulated, changed passed on to third parties, translated or used otherwise, in full or in part, without Guntner GmbH & Co. KG's prior explicit written approval.

1.5 Operating instructions

1.5.1 Scope

These operating instructions apply to all evaporators of the GACA RX series.

NOTICE

You will find the precise type of your unit in the attached order-related documents.

1.5.2 Set-up and other applicable documents

The unit's operating instructions include the following parts:

- These instructions
- Order-related documents
The order-related documents are included with these instructions and contain the following information:
 - The order-related proper use as specified
 - The order-related scope of delivery
 - The order-related technical data
 - The order-related drawings specifying customer, project number and order number
- Motor connection wiring diagram in terminal boxes

These operating instructions are part of the operating instructions manual of the system, provided by the system's installer.

1.6 Conventions

1.6.1 Typographical conventions

The following text markups are used in these operating instructions:

Bold	Requires special attention!
Grey triangle	Instructions

1.6.2 List of abbreviations

Abbreviations	Meaning
CFC/HFC	Alkane group refrigerant, e.g. R134a, R404A, R407C, ...
EN 378	European Norm 378: Refrigeration systems and heat pumps; safety-related and environmental requirements
EN	European Norm
DIN	German industrial standard (specification of a standard)
ISO	International Standardization Organization .
°C	Degrees Celsius (Celsius scale temperature)
is	Unit of pressure
l	Litre (liquid volume)
Vol%	Volume percent (concentration level relative to a volume)
IP	Insulation protection
Q 6,3	Balancing quality
ppm	parts per million, concentration figure, stands for "millionth part".
Hz	Hertz (frequency)
D	Delta connection (alternating current: high speed)
S	Star connection (alternating current: low speed)
3~	3-phase current
1~	1-phase alternating current
VDE	"Verband der Elektrotechnik, Elektronik und Informationstechnik" (Association for Electrical, Electronic & Information Technologies)
TCC	Technical Connection Conditions
EPC	Electric Power Company
VDI	"Verein Deutscher Ingenieure" (German engineers' association)

1.7 Conventions for safety signs and notices

1.7.1 General safety signs and their meaning in these operating instructions

DANGER

Dangerous situation that will definitely cause serious injury or death if it is not avoided.

WARNING

Dangerous situation that could cause serious injury or death if it is not avoided.

CAUTION

Dangerous situation that could cause slight to moderate injury if it is not avoided.

NOTICE

Refers you to possible damage to property.

1.7.2 Warning symbols and their meaning in these operating instructions



Warns against hand injuries!

Failure to comply with warnings may result in hands or fingers being crushed, dragged in or otherwise injured.



Warns against hot surfaces!

The temperature is over +45°C (at which protein clots) and can cause burns.



Warns against cold!

The temperature is below 0°C and can cause frostbite.



Warns against dangerous electrical voltage!

Danger of an electric shock if voltage-carrying parts are touched.



Warns against harmful to health or irritant substances at set-up point

Contact with or inhaling substances that are irritant or harmful to health can cause injuries or damage peoples' health.



Warning of automatic start-up

If the unit starts up automatically during maintenance work there is a danger of pinching/trapping the hands and fingers.

1.7.3 Prohibitory signs and their meaning in these operating instructions



Fire, open fire and smoking prohibited!

Ignition sources must be kept away and ignition sources must not develop!



No smoking!

Smoking is forbidden.

1.7.4 Mandatory signs and their meaning in these operating instructions.



Use eye protection!

Eye protection: Use protective cover, protective glasses or face protection.



Use hand protection!

Protective gloves must protect against mechanical and chemical dangers (see imprinted pictograms).



Use respiratory protection!

Breathing apparatus must be suitable for the working fluid used. Breathing apparatus must consist of:

- At least two independent breathing devices (self-contained breathing apparatus)



Use protective clothing!

Personal protective clothing must be suitable for the working fluid used and for low temperatures, and must have good heat insulation properties.



Activate before work!

Activate the electrical system and secure against switching on again before starting installation, maintenance and repair work.

2 Safety

2.1 Labelling on the unit:

Placing identifiers on the unit

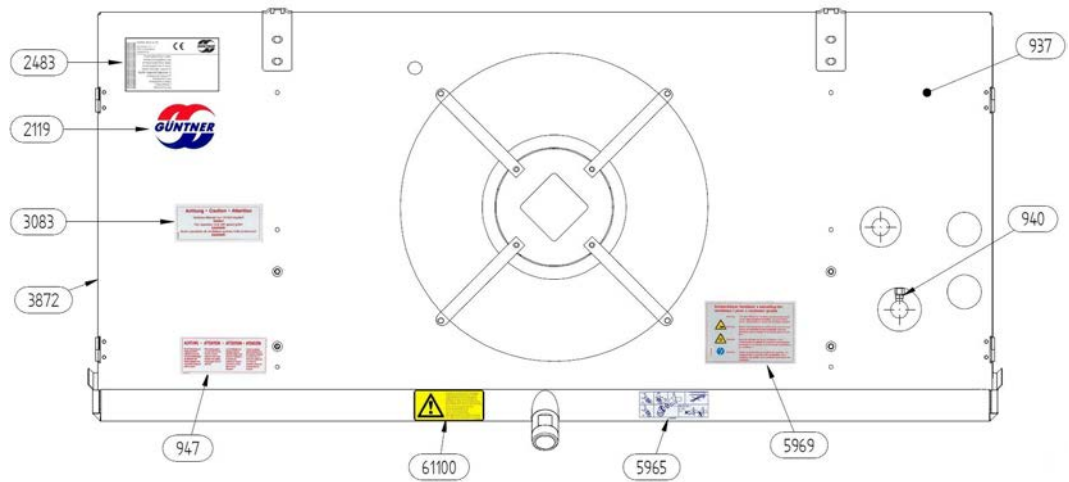

Identifiers on the unit - Front

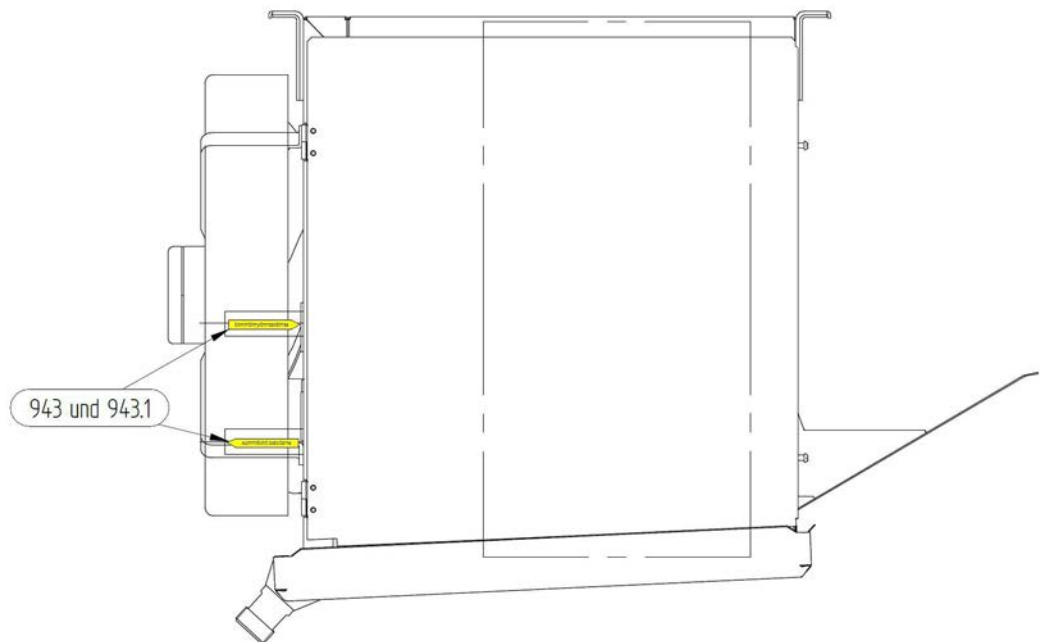

Identifiers on the unit - Side

2.1.1 Safety signs on the unit

Safety signs on the unit individually:

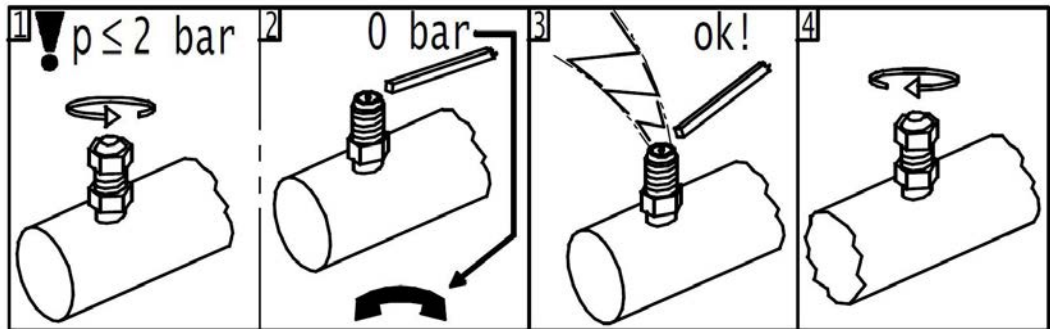

940 - "Transportation filling" warning sign next to Schrader valve

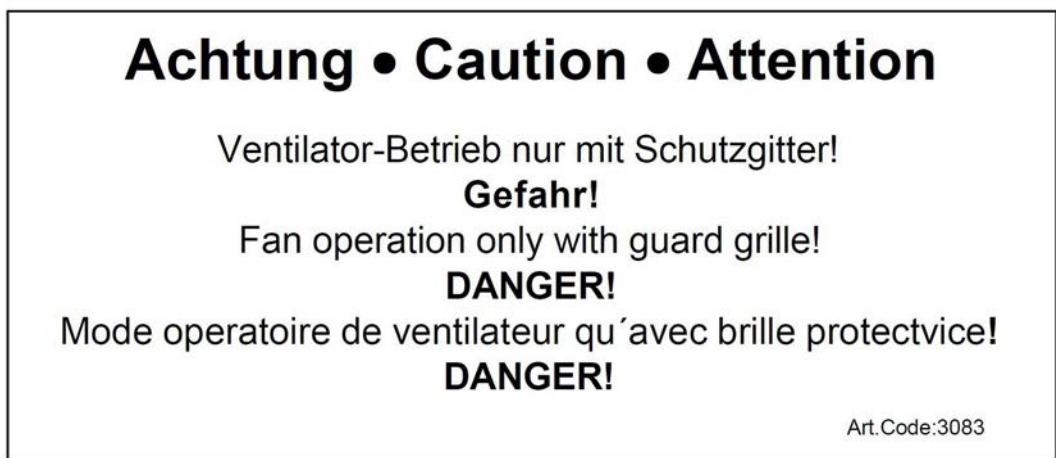

3083 - "Protection grill" warning sign (only used with separate removable protection grill)

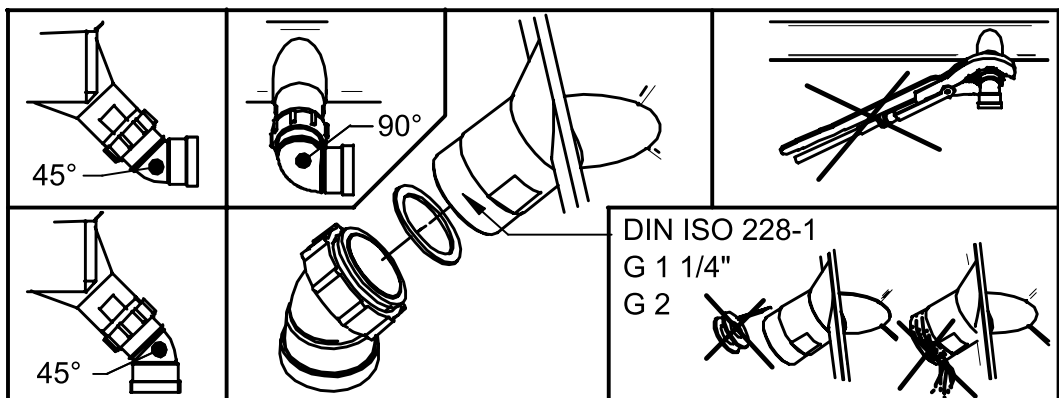

5965 - Tray drain warning sign

**Schwenkbarer Ventilator • swivelling fan
ventilateur à pivot • ventilador girable**

Achtung: Vor dem Öffnen der Ventilatorverschraubung Gerät immer **spannungsfrei schalten**, da sonst Gefahr durch automatischen Anlauf des Ventilator besteht!

Warning: Before unscrewing the fan screw joints, the unit must always be **switched to zero potential**, because otherwise there is danger of automatic start-up of the fan!

Attention: Avant de dévisser les vis du ventilateur, il est indispensable de **mettre le ventilateur sans tension**, autrement, il y a le danger d'un démarrage automatique du ventilateur!

Atención: Antes de destornillar los tornillos del ventilador, es indispensable el aparato esté **sin tensión**, de lo contrario, hay peligro de un arranque automático del ventilador!

Art.-Code 5969

5969 - "Swivel fan" warning sign

Während der Wartungsarbeiten ist der Aufenthalt im Gefahrenbereich unter dem Gerät VERBOTEN!
Kondensatwanne kann sich bei unsachgemäßer Handhabung vom Gerät lösen und herabstürzen. Beim Öffnen der Wanne muss mit erhöhtem Wannengewicht infolge von Eis und Wasser gerechnet werden!

Do not stay in the hazardous zone below the unit during maintenance work!
The drip tray can loosen and fall down in case of improper handling. When opening the drip tray, be aware that the drip tray's weight can be increased due to ice or water!

Art.-Code 61100

61100 - Tray safety catch warning sign

2.1.2 Other signs and notes on the unit

Güntner GmbH & Co.KG Hans-Güntner-Straße 2-6 82256 Fürstenfeldbruck www.guentner.de			
			
Projektnummer – Project number			
Gerätebezeichnung - Device type			
Gerät Seriennummer - Device serial number			
Ventilator / ID / Drehzahl - Fan / ID / Speed			
Umgebungstemperatur – Air ambient temperature			
Herstellungsjahr - Year of manufacture			
* Wärmetauscher Seriennummer 1/2 - Coil serial number 1/2			
* Wärmetauscher Seriennummer 3/4 - Coil serial number 3/4			
Volumen 1/2/3/4 – Volume 1/2/3/4			
Max. zulässiger Druck (PS) Max. allowable pressure (PS)		___ bar	___ bar
Zulässige max./min. Temperatur (TS) Allowable max./min. temperature (TS)		___ °C	___ °C
Prüfdruck (PT) / Prüfmedium Test pressure (PT) / Test medium		___ bar / Druckluft - Compressed air	
Prüfdatum 1/2/3/4 – Test date 1/2/3/4			
Fluidgruppe / Zustand - Group of fluid / State			

2483 - Sample view of a manufacturer's nameplate



2119 – Logo



943 and 943.1 - Connections IN and OUT

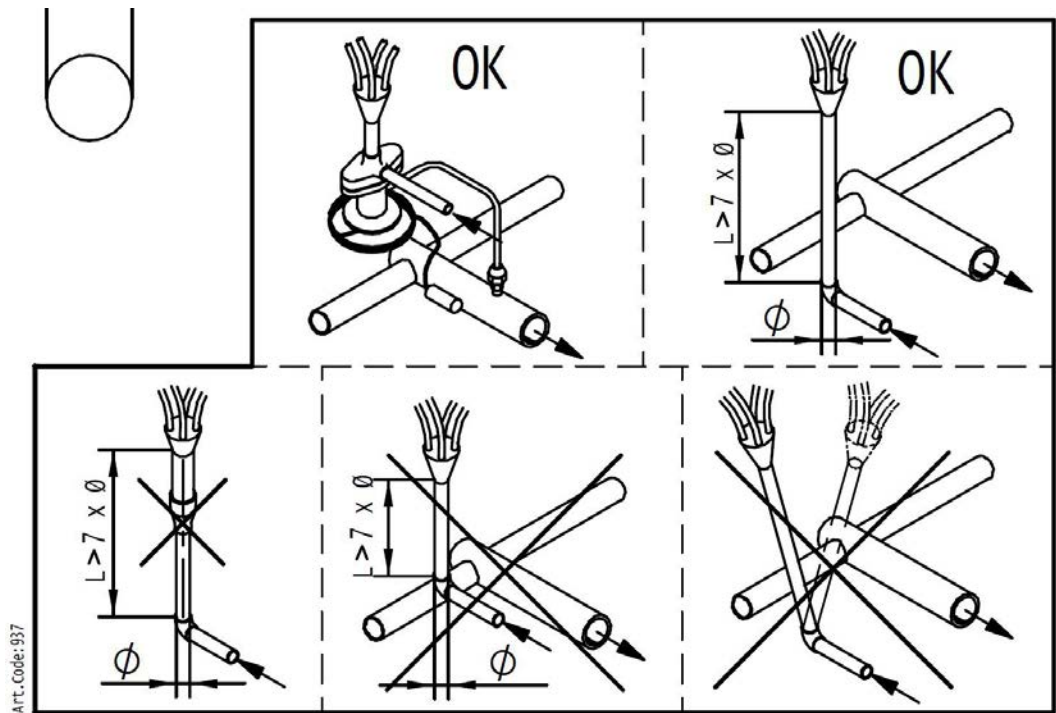

937 - Expansion valve mounting

ACHTUNG – ATTENTION – ATTENTION – ATENCIÓN

Bei der Verwendung von Reinigungsmitteln in Kühlräumen, ist auf die Korrosionsbeständigkeit der Materialien des Kühlers gegenüber dem verwendeten Reinigungsmittel zu achten!

When cleaning agents are used inside the cold room, the corrosion resistance of the cooler materials to the applied cleaning agent has to be observed!

Lors de l'utilisation des détergents dans les chambres froides, il faut observer la résistance à la corrosion des matériaux de l'appareil qui entrent en contact direct avec les détergents.

Cuando se apliquen agentes limpiadores en los productos instalados en cámaras frías, se debe tener cuidado que no corraen los materiales usados para la construcción del producto!

947 - Corrosion resistance

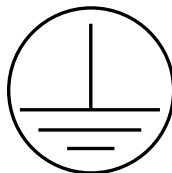

3872 - Earthing identifier

2.2 Basic safety notices

2.2.1 How to act in an emergency

WARNING

Danger of injuries!

the CFC/HFC refrigerants that are used (R134a, R404A, R407C, ...) are Group L1/A1 refrigerants compliant with classification according to flammability (L) and toxicity (A) in compliance with EU Directive 97/23/EC for pressure equipment (Pressure Equipment Directive):

- Refrigerants that, when gaseous, are non-flammable irrelevant of their concentration in air.
- Refrigerants with a time-weighted, averaged concentration that have no adverse effects on the majority of staff that are exposed every day during a normal 8 hour working day and a 40 hour working week to this concentration, which is greater than or equal to 400 ml/m³ (400 ppm (V/V)).

There is no imminent danger for the staff. However, refrigerants of the Group L1/A1 are generally heavier than air and may flow off to rooms on a lower level. In still air there may be an increase of the ground level concentration. With high concentrations there is a danger of suffering from disordered cardiac rhythm and suffocation due to a reduced oxygen concentration, especially at ground level.

Unauthorised people must not have access to the unit. Please ensure that the CFC/HFC refrigerant escaping from the unit cannot penetrate the interior of the building or put people at risk in any other way.

Safety measures and procedure:

- In the event of serious unexpected leakage of refrigerant, leave the set-up room immediately and activate the emergency measures provided, e.g. if:
 - Visibly escaping refrigerant liquid or vapour from the heat exchanger or pipe components.
 - there is a sizeable sudden escape (escape and evaporation of the greater part of the entire refrigerant filling within a short time, e.g. in less than 5 minutes);
 - Activation of the refrigerant detector (limit value in accordance with EN 378-1; Annex E);
- Have experienced, trained personnel with prescribed protective clothing perform all necessary protective and other measures:
 - Use respiratory protection.
 - Use a room air-independent breathing apparatus with maintenance work in high refrigerant concentrations in the room air.
 - Ensure the set-up room is well ventilated in accordance with EN378-3 .
 - Divert escaped refrigerant vapour and escaped refrigerant liquid safely.
 - Ensure that no refrigerant enters water systems or sewage.

2.2.2 Personnel, care requirements

CAUTION

The unit may be installed, put into operation, operated, maintained and repaired only by trained, experienced and qualified personnel. In order to be considered qualified, people who are to be responsible for the operation, maintenance, repair and evaluation of systems and their components must have the necessary training and specialist knowledge for such work, as stipulated in EN 378-1. Qualified or expert means the ability to satisfactorily perform the activities required for the operation, maintenance, repair and evaluation of refrigeration systems and their components.

The unit may be operated by operating personnel that have no specific knowledge of refrigeration engineering, but have sufficient knowledge and experience with regard to the mode of operation, operation and daily monitoring of this system. This operating personnel may not make any interventions or settings on the system.

Changes to the unit, which the manufacturer has first agreed to in writing, may only be made by the instructed and qualified personnel.

Electrical installation:

Work on the electrical equipment may only be performed by personnel that have the required expertise (e.g. an electrician or an electro-technically instructed person), and who are authorised by the operator, in compliance with the respective VDE regulations (and national and international provisions) and the TCCs of the EPCs.

2.3 Proper intended use

2.3.1 Proper intended use

CFC/HFC evaporators of the GACA RX series are intended for installation in a refrigeration system and are used for cooling and circulating the room air in

The unit is delivered for operation with a specific operating point:

- Evaporation temperature
- Airflow volume
- Air inlet temperature

The specified operating point is given in the order-related documents.

2.3.2 Operating conditions

The unit is a component a cooling system including its working fluid circuit. The purpose of these operating instructions, as part of the operating instructions manual (of which these operating instructions are a part), is to minimise the danger to people and property and the environment from the unit and the working fluid used in it. These dangers are essentially connected with the physical and chemical properties of the working fluid and with the pressures and temperatures that occur in the working fluid-carrying components of the unit [see Residual hazards due to CFC/HFC refrigerants, page 23](#).

WARNING

Danger of injuries and damage to property!

The unit may be used only in accordance with the proper intended use. The operator must ensure that when operating, monitoring and maintaining the unit, the fluid used and the mode of operation do not deviate from the order-related information specified in the order-specific documents.

The operator must ensure that maintenance measures are performed in compliance with the system's operating instructions manual.

Filling the unit with a different fluid is permitted only following written approval by the manufacturer. You will find the order-related proper use as intended in the order-specific documents.

Do not exceed the max. operating pressure given on the unit's type plate.

2.3.3 Improper use

WARNING

Danger of injuries and damage to property!

Working fluids and their combinations with water or other substances in the working fluid-carrying components have chemical and physical effects from the inside on the materials surrounding them. The unit may be pressurised only with CFC/HFC refrigerant. Pressurising the unit with another working fluid would have the effect that

- the structural, soldering and welding materials used do not withstand the foreseeable mechanical, thermal and chemical stresses, and the pressure that can occur during operation and when shut down is not withstood.
- material, wall thickness, tensile strength, corrosive resistance, shaping process and testing are not suitable for the working fluid used and do not withstand the possible pressures and stresses that might occur.
- the unit would not be resistant to the other working fluid and the combination of the other working fluid and
- the unit not remaining tight during operation and when shut down.
- a possible sudden escape of working fluids could directly endanger people and/or property and the environment.

The maximum permissible operating temperature specified on the type plate must not be exceeded! If the operating temperature is exceeded,

- the unit would be exposed to an impermissibly high pressure (pressure/temperature correlation),
- signs of material fatigue would emerge,

The maximum permissible operating pressure specified on the type plate must not be exceeded! If the operating pressure is exceeded,

- the parts of the unit carrying the working fluid might not withstand the foreseeable mechanical, thermal and chemical stresses and the pressures that may occur during operation and when shut down,
- the unit would not remain tight during operation and when shut down,
- there may be a possible sudden escaping of working fluids after a break or leakage on working fluid-carrying components, which would result in the following dangers:
 - Danger of escaping materials
 - Dangers caused by oxygen displacement
 - Fire hazard (caused by refrigerator oil parts)
 - danger of frostbite (caused by liquid coolant squirting/splashing),
 - Suffocation hazard
 - hazards caused by panic reactions,
 - Environmental pollution

WARNING

CFC/HFC evaporators may not be used

- where it is possible that short or prolonged effect caused by contact, inhalation or ingestion of the working fluid might result in harmful hazards.
- where the possibility exists of a sudden large release (release and evaporation) of the greater part of the entire working fluid filling in a short time (e.g. in less than 5 minutes).

The unit must not be changed without the prior written consent of GÜNTNER GmbH & Co. KG. Changes to the unit are:

- Changing the operating point (as specified in section [see heat exchanger \(typical values\), page 29](#))
- Changing the fan capacity (air volume)
- Changing the working fluid flow-through volume
- Changing over to another working fluid

The unit must not be operated if safety devices recommended by the manufacturer are not available, not properly installed or not fully functional.

The unit must not be operated if it is damaged or demonstrates faults. All damage and faults must be reported to Guntner GmbH & Co. KG immediately and dealt with promptly.

Work on the unit must not be performed without the personal protective equipment specified in these operating instructions.

2.4 Mechanical residual hazards

2.4.1 Fins, sharp unit corners and edges

WARNING



Warns against hand injuries!

Danger of cuts on hands and fingers on the fins and on sharp corners and edges of the unit.



Use reliable hand protection!

2.4.2 Flap down drip tray

WARNING

Warning against personal injury and damage to property!

Danger of falling unit parts, masses of water or ice when the drip tray is flapped out.

Nobody is allowed to be in the danger area below the unit during cleaning or maintenance work.

The drip tray can be flapped down for cleaning and is protected from falling down by a safety catch.

Unit parts, masses of water or ice can nonetheless fall down when it is flapped down.

2.4.3 Fans

⚠ WARNING



Danger of cutting off, pulling in!

There is a danger of cutting off fingers on the rotating fan blades, injury hazard for the hands and pulling in danger for loose elements such as hair, necklaces or clothing parts.



Do not operate fans without guard grille. Pinch/trap point hazard!

With automatic fan start during maintenance work there is a danger of pinching/trapping for the hands and fingers.



Power off the unit before you begin maintenance work with which you must remove the guard grille. Secure the unit against unintentional switching on again by removing the electric fuses for the unit. Secure the unit with a suitable warning sign referring to unintentional switching on.

2.4.4 Hinged side plates

⚠ WARNING



The removable side plates may be opened only by trained specialist staff and only for maintenance and repair purposes. The first time it is opened the screws will need to be loosened. The screws do not need to be moved for subsequent opening and closing. Close the removable side plates after completing the work and secure them against unintentional or unauthorised opening!



Caution!

The snap lock must not be secured at the manufacturer side. The operator must ensure the securing.

2.5 Electrical residual hazards

WARNING



Warns against dangerous electrical voltage!

Direct and indirect contact with voltage-carrying parts of motors and electrical lines can cause serious injuries or death.



Power off the unit before you begin maintenance work. See the refrigeration system's system documentation for this. Secure the unit against unintentional switching on again by removing the electric fuses for the unit. Secure the unit with a suitable warning sign referring to unintentional switching on.

Please note that the mains cables may also be carrying voltage, even if the unit is powered off.

Work on electrical equipment may be performed only by people that have the required expertise (e.g. an electrician or an electro-technically instructed person) and who are authorised to do so by the operator.

2.6 Thermal residual hazards

2.6.1 Danger of burns

WARNING



Warns against hot surfaces!

Use hand protection!



2.6.2 Frostbite hazard

⚠ WARNING



Warns against cold!

In refrigeration operation the heat exchanger and pipes have a temperature below ± 0 °C. Contact can cause frostbite.

Use hand protection!



2.6.3 Overheating

NOTICE

Risk of material damage due to overheating!

If the optional electrical heating straps are used for reheating while the fans are at a standstill, this may cause the inside of the unit to overheat, which would damage it.

The optional electrical heating straps should be used for reheating only while the fans are running!

2.7 Residual hazards due to CFC/HFC refrigerants

The CFC/HFC refrigerants that are used (R134a, R404A, R407C, R507 ...) are Group L1/A1 refrigerants in compliance with classification according to flammability (L) and toxicity (A) in compliance with EU Directive 97/23/EG for pressure equipment (Pressure Equipment Directive):

- Refrigerants that, when gaseous, are non-flammable irrelevant of their concentration in air.
- Refrigerants with a time-weighted, averaged concentration that have no adverse effects on the majority of staff that are exposed every day during a normal 8 hour working day and a 40 hour working week to this concentration, which is greater than or equal to 400 ml/m³ (400 ppm (V/V)).

There is no imminent danger for the staff. With good air ventilation and removal by suction, it will fall easily and clearly below the allowed limit values.

⚠ WARNING

Danger of harm to health and environmental damage!

Refrigerants of the Group L1/A1 are generally heavier than air and may flow off to rooms on a lower level. In still air there may be an increase of the ground level concentration. With high concentrations there is a danger of suffering from disordered cardiac rhythm and suffocation due to a reduced oxygen concentration, especially at ground level.

- Unauthorised people must not have access to the unit.
- Ensure working rooms are well-ventilated in order to prevent inhalation of high vapour concentrations.
- Please ensure that the CFC/HFC refrigerant escaping from the unit cannot penetrate the interior of the building or put people at risk in any other way. CFC/HFC refrigerant vapour must be kept

from penetrating neighbouring rooms, staircases, yards, passages or drainage systems and must be discharged without risk

- Monitor the CFC/HFC refrigerant concentration in the ambient air to ensure constant compliance with limit values.
- Test the tightness of the unit regularly, as specified in these operating instructions ([Inspection and maintenance plan, page 53](#)).



Ignition and fire hazard!

- With work involving fire or sparks, e.g. grinding, welding, etc., ensure suitable fire fighting equipment is on-site.
- In particular be aware of the danger of ignition of unintentionally carried in oil residues or CFC/HFC refrigerant.
- Ensure that the provided fire fighting equipment is provided in sufficient quantities, that it functions properly and that the extinguishing agent does not react with the CFC/HFC refrigerant.
- Smoke during work is forbidden!



Frostbite hazard

Splashes of CFC/HFC refrigerant that is superheated can cause frostbite to the eyes and skin.

- When removing faults after spills of CFC/HFC refrigerant, you must be vigilant for any remaining superheated CFC/HFC refrigerant.



Danger of poisoning!

CFC/HFC refrigerant contact with fire can form toxic combustion products.

- Prevent CFC/HFC refrigerant contact with open fire.
- Welding and soldering may therefore take place only after completely draining the relevant section of the system of the CFC/HFC refrigerant. Ensure good ventilation here!
- With emergency work in high refrigerant concentrations in the room air wear a room air-independent breathing apparatus.



2.8 Residual hazards caused by vibrations

WARNING

Danger of injuries and damage to property caused by escaping materials

If fans are damaged during fan operation, flying parts of the fan blades can injure people or cause damage to property close to the fan.

Fans, components and cables in system, must be designed, constructed and integrated so that dangers caused by vibrations that it or other parts of the system generate, are reduced to an absolute minimum, while incorporating all available means for reducing vibrations, preferably at the source.

NOTICE

Damage to property caused by vibrations

Vibrations that are increased by imbalances, as created by dirt, frosting, icing or fan blade damage, are regularly caused with fan operation. The vibrations are transferred to the unit, where they can cause damage and damage the unit mounting or components connected to the unit.

Check fan blades and protection grill regularly for contamination and make sure the fans run smoothly (see Fans, page 53).

2.9 Residual hazards caused by pressurised parts

⚠ WARNING

Injury and damage to property caused by pressurised parts that contain CFC/HFC refrigerant!

Breaks in pressurised pipes or pressurised components of the unit can cause injuries or damage to property caused by escaping materials (A sudden large release of the working fluid with its hazardous properties after a break or leak on pressurised components of the unit can cause the following hazards:

- Oxygen displacement
- Flammability caused by proportion of lubricating oil for refrigerating compressors present
- Frostbite (caused by liquid refrigerant squirting/splashing)
- Suffocation
- Panic,
- Environmental pollution

Ensure that the unit in question is pressure-free before maintenance work begins or remove the working fluid from the unit in question.

Perform maintenance work – especially soldering and welding – on the unit in question only after completely removing the working fluid from the unit.

2.10 Residual hazards caused by defective installation

⚠ WARNING

Injuries and damage to property caused by defective installation!

Defective installation results in hazards caused by:

- Break or leak on liquid-carrying unit components and pipes
- Uneven load distribution on the fixtures with the danger of stresses within the unit or unit displacement (breaks or leaks on fluid-carrying components of the unit and pipes; danger of breaking off).
- Insufficient securing of working fluid-carrying lines against mechanical damage! On-site connections: loaded installation; effect of forces on the distribution and header pipes with the danger of breaks or leaks on fluid-carrying components of the unit and pipes; danger of breaking off!
- Danger of damage caused by environment-conditional hazard sources (production, transport and other processes at the set-up point).
- Unit functional faults caused by air inlet/outlet obstructions.
- Obstruction of all-side inspection, checks and maintenance, i.e. no unobstructed accessibility to the working fluid-carrying and electrical components, connections and cables, no recognisable identifiers on the pipes and insufficient space for tests.

Ensure that:

- The units are to be installed on the fixing points corresponding with their weights and tightened with fixing bolts. The operator or installer is responsible for ensuring that the bolted connections are of an adequate strength.
- The diameters of the mounting holes have been statically determined by the manufacturer and the fixing bolts are adapted accordingly.
- The fixing bolts are secured against loosening by means of an appropriate locking device.
- The fixing bolts are not overtightened or stripped.
- All fixing bolts are tightened equally to achieve a load distribution on the connections that is as balanced as possible.
- All fixing points maintain the same spacing to the fixing level permanently and under load, so that no mechanical stress occurs in the unit structure. The units are anchored in their fixing position in order to prevent the equipment from moving.
- The functional safety of the fixing bolts is tested as part of the maintenance periods. [see Maintenance, page 52](#).
- The unit is fixed and set up so that it is not damaged by environment-conditional hazard sources (production, transport and other processes at the set-up point) or its functioning is not disturbed by the interventions of unauthorised persons.
- The units are fixed and set up so that unobstructed air inlet/outlet is constantly available without any air short circuiting.
- The units are fixed so that they can be inspected, checked and maintained from all sides at all times, i.e. there must be unobstructed access to the refrigerant-carrying and electrical components, connections and lines, the pipeline labelling must be identifiable and adequate space must be available for testing.
- The working fluid-carrying lines must be protected against mechanical damage. On-site connections: when installing keep the unit free of load; force must not be exerted on the distribution and header pipes.
- The following must be observed without fail when installing the unit:
 - Imperative adherence to spacing from objects that could be endangered by an effect of the CFC/HFC refrigerant.
 - Provision of measures to safeguard protective objects from a CFC/HFC refrigerant concentration higher than that permitted by EN 378-3.
 - Easily flammable materials must not be placed below the unit.
 - Set up and fix units as follows: In areas that are used for inner-plant traffic, the pipelines to and from the unit must be installed only with connections and fittings that cannot be removed.

2.11 Residual hazards with break during operation

WARNING

Injuries and damage to property caused by break during operation!

- Defective installation ([see Residual hazards caused by defective installation, page 25](#)).
- Non-compliance with maximum permissible operating pressure ([see Operating conditions, page 18](#)).
- Disregarding pressurised line sections with maintenance ([see Residual hazards caused by pressurised parts, page 25](#)).
- Disregarding residual hazards caused by vibrations ([see Residual hazards caused by vibrations, page 24](#)).

result in ruptures during operation and maintenance. This results in dangers caused by

- escaping materials ([see Residual hazards caused by pressurised parts, page 25](#)).
- released working fluid ([see Residual hazards due to CFC/HFC refrigerants, page 23](#)).

Ensure that:

- The installation is fault-free.
- The maximum permissible operating pressure is always adhered to.
- Pressurised line sections are de-pressurised before all maintenance and repair work.
- Vibrations from the refrigeration system, from the (vibrations caused by system compressors, , components and lines) and from the fan (imbalances caused by frosting, icing or dirt build-up or damages) are reduced with all available means and brought down to an absolute minimum.
- Release devices to prevent liquid escapes are provided and available.
- Undercooled liquid is only present in the lowest possible amount in system sections in shutdown state – minimized number of "fluid sacks".
- When switching over a duty pump to a reserve pump no liquid, cold refrigerant remains in the pump.

2.12 Residual hazards caused by escaping objects or liquids

WARNING

Injuries and damage to property caused by escaping objects or liquids!

Residual hazards caused by escaping objects and liquids ([see Residual hazards with break during operation, page 26](#)).

2.13 Residual hazards with disposal

WARNING

Danger of injuries and damage to property caused by CFC/HFC working fluid, , !

The following notes are recommendations for the proper professional disposal of the unit. Applicable waste disposal laws are binding for the country of operation:

- Disposal must only be carried out by experts.
- All unit components, e.g. working fluids, refrigerator oil, heat exchangers, fans, must be disposed of properly as specified.
- Used working fluid that is not determined for reuse, must be treated as waste and safely disposed of. There must be no emissions into the environment.
- The CFC/HFC refrigerant must be filled into a special refrigerant container in compliance with the respective safety measures. This special refrigerant container must be suitable for the refrigerant. It must be easy to identify and labelled for the refrigerant, e.g. "HFC R-4304A recovered".
- A disposable single-use container must not be used, as refrigerant vapour residues in the container escape during disposal.
- The working liquid receiver must not be overfilled. The maximum permissible pressure of the working fluid container must not be exceeded during the work process.
- The working fluid must not be filled in a liquid container that contains another or an unknown working fluid. This other or unknown working fluid must not be released into the atmosphere, but rather identified, treated again, or properly disposed of as specified.
- An officially authorised facility can be used for destroying the working fluid.
- Used refrigerator oil that has been recovered from the unit and cannot be treated again, must be kept in a separate, suitable container, treated as waste and safely disposed of.

- It must be ensured that all unit components containing working fluids and refrigerator oil, are disposed of properly as specified.
- Before scrapping the working fluid-carrying unit components must be drained, whereby the pressure must be reduced to at least 0.6 bar absolute for a unit pipe volume up to and including 200 l, and to 0.3 bar absolute for a unit pipe volume over 200 l. The pressure reduction process is then ended when the pressure no longer increases and remains constant, and the unit is at ambient temperature.

 **WARNING**

Danger of environmental pollution!

The facility for recovering or disposing of the refrigerant must be operated so that the danger of a refrigerant or refrigerator oil emission into the environment is kept as low as possible.

- Ensure that no working fluid enters water systems or sewage.
- Operate the facility for recovering or disposing of working fluids so that the danger of a working fluid or refrigerator oil emission into the environment is kept as low as possible.

Güntner GmbH & Co. KG's transportation packaging is made from environmentally compatible material and is suitable for recycling.

3 Technical data

3.1 heat exchanger (typical values)

NOTICE

The fans' capacity values depend on the ambient temperature and on the air resistance at the set-up point.

Güntner GmbH & Co. KG recommends electric fan ring heating with use in the temperature range.

Please consult the manufacturer when operating the unit below -40°C because of the special material requirements and selection.

All electrical parts must be installed in accordance with EN standards.

Project number	See order-related documents
Unit name	See order-related documents
Manufacturer number	See order-related documents
Production year	See order-related documents
Working fluid	See order-related documents
Volume	See order-related documents
Maximum permissible pressure (PS)	0 - 32 bar
Test pressure	35.2 bar
Test pressure	17.6 bar
Permissible ambient temperature	-30- +40 °C
Permissible air humidity	> 100%
Test date	See order-related documents
Test medium	Dry air
Airborne noise emitted	See order-related documents In accordance with the standard procedure for calculating sound level described in EN 13487; Annex C (normative). As cold storage rooms have only very low absorption behaviour, we recommend you to expect only very low absorption of the sound level at large distances.
Weight	See order-related documents

3.2 Fans

Fan type	See order-related documents
Protection rating	At least IP 44 in accordance with DIN 40050
Type of current	1~ AC (up to Ø400 mm) or 3~ three-phase current(from Ø 450 mm)

Voltage	230 V 50 Hz or 230 V 60 Hz from Ø 450 mm: 400 V 50 Hz
Permissible air temperature	Operating range: -30°C to at least +40°C
Protective devices	<ul style="list-style-type: none">• Thermal: Motor contactor external by thermocontacts (openers)• Mechanical: Protective contact grille in accordance with EN 294

4 Set-up and function

The air cooler consists of,

- a heat exchanger arranged as consisting of pipe coils fitted with fins (copper pipe; aluminium fin) distribution and header pipes (copper)/ and pipe connections to the pipeline system,
- an aluminium-magnesium alloy casing, powder-coated RAL 9003 (signal white); brackets for ceiling fixing made of stainless steel, flush with housing top edge;
- a thermally-decoupled and therefore condensation-free drip tray made of AlMg, powder-coated RAL 9003 (signal white). The drip tray is hinged and removable for easier cleaning. Problem-free condensation water drain; 45° drain nozzles mounted using flat-sealing G threads as described in DIN ISO 228-1,
- and – depending on the version – with one or more axial fans with external rotor motors wired on a terminal socket.

The evaporator is a refrigeration system component. It provides a finned heat exchanger (straight and curved pipes – pipe coils – with fins, which are connected to form a heat exchanger) in which liquid refrigerant evaporates by absorbing heat from the material to be cooled.

The refrigeration system is a combination of refrigerant-carrying components and fittings connected with one another, which form a closed circuit, in which the refrigerant circulates.

The refrigerant absorbs heat at a low temperature and low pressure and evaporates (evaporator-side), and at a higher temperature and higher pressure gives off the heat again and condenses itself (condenser-side).

The heat from the material to be cooled is dissipated with fans over the entire surface of the evaporator.

The GACA RX series evaporators standardly operate in accordance with the “dry evaporation” principle. The refrigerant liquid fed to the evaporator is completely evaporated in it, and overheated to protect the compressor from slugging. The CFC/HFC refrigerants used (R134a, R404A, R407C, ...) are Group L1/A1 refrigerants ([see Residual hazards due to CFC/HFC refrigerants, page 23](#)).

5 Fan motor

NOTICE

During longer periods of storage or standstill, the fans must be activated during 2 to 4 hours per month.

NOTICE

For fans with the protection rating IP55 or higher, existing closed condensation water holes must be opened at least once every six months.

AC technology

The AC motors are protected against overheating by a thermocontact (or PTC resistor).

For motors with a thermocontact, the thermocontact must be switched in such a way that the motor cannot be powered on when the thermocontact is triggered. A locking mechanism is recommended to prevent renewed power-on.

Motors with a PTC resistor need an additional external trigger unit for the installed thermistors. A locking mechanism is recommended to prevent renewed power-on. The test voltage at the thermistors is not permitted to exceed 2.5 V, or only current-limiting test devices may be used.

When using a star-delta connection, a corresponding delay must be considered.

For motors with direct starting and a connection value > 4.0 kW, an inrush current limitation (soft start using a thyristor) could be required.

If frequency converters are to be used for speed control, the following points must be considered for external rotor fans:

Between the frequency converter and fans, all-pole sine-wave filters must always be installed (sine wave-shaped output voltage; filter effect between phase to phase and phase to earth).

All Guntner frequency converters are equipped with this function as standard. Conventional three-phase motors are suitable for direct operation with frequency converters.

With star-delta connection, the three-phase fan motors can be operated with two speeds or with speed control. The direction of rotation must be checked. A change in the direction of rotation, if it is wrong, is made by interchanging two phases.

6 Transportation and storage

6.1 Safety

⚠ WARNING

Crushing danger with falling down!

The unit weighs between 73 kg and 570 kg. It can slip and fall off the transporting device, causing serious injuries or death. Heavy impacts or vibrations can damage the unit.

Ensure that the assigned staff is trained for proper unloading.

Ensure that nobody is under the unit or near the loaded area during the transport.

Ensure even weight distribution. Ensure that the bulk of the weight is always on the fan side. Observe the transport labels on the packed unit ([see Other signs and notes on the unit, page 15](#)).

Secure the unit against slipping and mechanical damage.

Use auxiliary transport equipment where required. Use a transporting device appropriate for the unit's weight. You will find the weight of the unit in the order-related documents [see Set-up and other applicable documents, page 7](#)). Do not use connection pieces and header pipes as hooking points for lifting, pulling, fixing or mounting. This can cause leaks.

Transport the unit carefully. Particularly avoid setting the unit down hard.

6.2 Transportation and storage

NOTICE

Read and observe all transport signs on the units' packaging!

Prolonged mechanical stresses caused by uneven road surfaces and potholes and vibrations during transport by ship can cause transportation damage. Before transportation by sea or in countries with difficult transport routes, attachment parts that are likely to vibrate – in particular fans and base stands – must be removed for transportation.

- ▶ Use suitable equipment to transport the packed unit to the destination installation site (for example, a crane or fork-lift).
- ▶ Unload the unit.

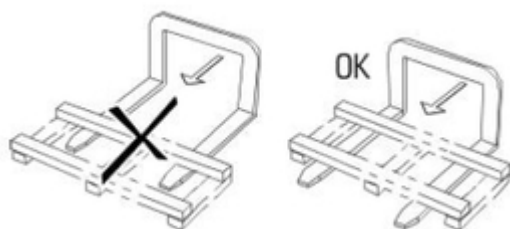

Unloading wooden crates

- ▶ (1) Use a forklift to unload the pallet.
- ▶ (2) If crates are stacked on top of one another, use a forklift truck to lift them off individually and place them at the installation site.

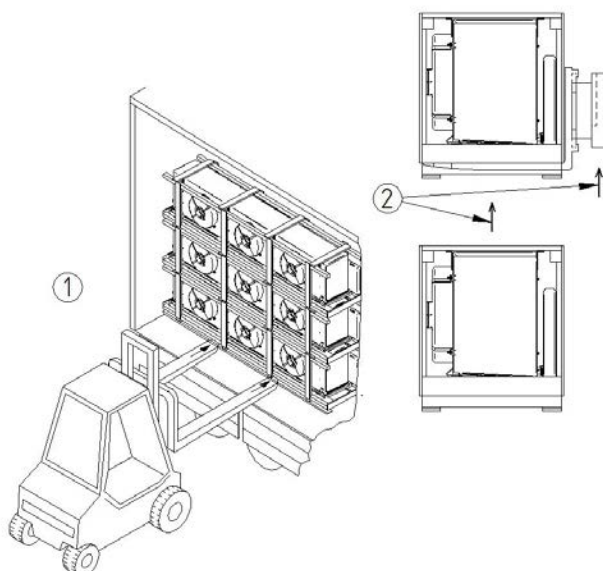

6.3 Storage before installation

NOTICE

Danger of corrosion and dirt build-up!

Moisture and dirt must be prevented from entering the unit.

- ▶ Protect the unit against dust, dirt, moisture and wetness, damage and other harmful effects. Harmful effects: [see Safety instructions for set-up and start-up, page 35](#)
- ▶ Do not store the unit for longer than necessary. Only store the units in their original packaging until installation. Always only place packaging units of the same size on top of one another.
- ▶ Store the unit at a protected place free of dust, dirt, moisture and damage-free until its set-up (well-ventilated halls or roofed storage site).
- ▶ If the unit set-up is delayed with regard to the planned installation time: protect the unit against weather and other harmful effects and dirt and other contaminants with an appropriate cover. The unit must also be well-ventilated here.

7 Set-up and start-up

7.1 Safety

7.1.1 Safety instructions for set-up and start-up

⚠ WARNING

Danger of injuries and damage to property with escaping CFC/HFC refrigerant!

Incorrect installation causes the danger of working fluid escaping when the unit is operated and injuries or damage to property ([see Residual hazards due to CFC/HFC refrigerants , page 23](#)).

Follow the set-up instructions in this chapter precisely and apply extreme care!

NOTICE

Damage to the system's !

Foreign materials and contaminants in the working fluid circuit can impair the effectiveness or damage components. Particularly harmful contaminants are:

- Moisture
- Atmospheric air
- Welding and soldering residues
- Rust
- Soot/ash/cinders
- Metal cuttings
- Unstable oils
- Dust and dirt of all kinds

Moisture in the working fluid-carrying components of the unit can have the following consequences:

- Water separation and ice formation cause faults in the switching and control fittings of the refrigeration system
- Acidification
- Ageing and refrigerator oil decay
- Corrosion

Atmospheric air and other non-condensable gases can have the following consequences:

- Refrigerator oil oxidation
- Chemical reactions between working fluid and refrigerator oil
- Increased condensing pressure in the system

Chemical reactions between working fluid and refrigerator oil with the absence of moisture or atmospheric air with ageing and working fluid and refrigerator oil decay can have the following consequences:

- Formation of organic and inorganic acids
- Increased compressed gas temperature in the system
- Corrosion
- Bad lubrication, increased wear and tear through to system or failure

Other contaminants can cause:

- Accelerated chemical processes (decomposition)
- Mechanical and electrical faults in the refrigeration system

During the installation (connecting the working fluid-carrying components of the unit to the working fluid-carrying system of the installation) ensure that internal contamination is strictly avoided.

Perform the installation with extreme cleanliness.

Finish all on-site pipe installation work before releasing the transport pressure!

Only release the transport pressure on the Schrader valve immediately before installation.

Only remove the sealing caps on the distribution and header pipe immediately before installation.

NOTICE

Danger of corrosion and dirt build-up!

Moisture and dirt must be prevented from entering the unit. If moisture and dirt penetrate the unit there is also the danger of damage to fittings and other system components of the .

Protect the unit against dust, contamination, moisture and wetness, damage and other harmful influences. Harmful influences are, for example:

- Mechanical: Damages caused by impacts, objects falling on or against, collisions with transport equipment, etc.
- Physical: Damages caused by close by concentrated flammable gases
- Chemical: Damages caused by contaminated atmospheres (salt, acid, chlorine, sulphur-containing, or similar)
- Thermal: Damages caused by close by heat sources

Begin with the installation as soon as possible.

⚠ WARNING

The electrical installation may be performed only by electricians (or by expert technicians with appropriate qualifications) in compliance with the relevant VDE rules (or applicable national and international regulations) and the TCCs of the EPCs!

7.1.2 System-side safety requirements

The unit is a component of an installation and can only be operated in conjunction with the installation

- All equipment required for operating the unit must be integrated into the switching and activation equipment :
 - Electrics: Fans and other electrical components, heating rods for electrical defrosting (optional) if applicable,
 - Working fluids: valves and fittings
 - Drip water: drip water drain line
- The working fluid-side and electrical connections must be available on the system. The connections must be specified in the order-related documents.
- The power supply of the fans must be provided in acc. with the specifications on the type plate on the fan motors.
- A switch-off device for preventing unexpected start-up (repairs switch), which separates all active conductors from the power supply (all-pole switch-off), must be provided for the fans in acc. with EN 60204-1.
- The fans' switch-on/off device must be secured (e.g. with a padlock) to prevent uncontrolled fan start-up.
- The electrical motor, repairs switch, terminal box and switching cabinet connections must be provided in acc. with the respective connection diagrams.

- It must be possible to shut off the unit if a leak occurs.
- People wearing ambient air-independent breathing apparatus in full protective clothing must also be able to activate all safety-relevant shut-off fittings.
- It must be possible to activate all devices meant for diverting escaping working fluids from a safe position.

7.1.3 Customer-side safety precautions

WARNING



Danger of injuries!

The unit contains CFC/HFC refrigerant ([see Residual hazards due to CFC/HFC refrigerants, page 23](#)).



The CFC/HFC refrigerants that are used (R134a, R404A, R407C, R507, R22 ...) are Group L1/A1 refrigerants classified according to their flammability (L) and toxicity (A) in compliance with EU Directive 2014/68/EG for pressure equipment (Pressure Equipment Directive):

- Refrigerants that, when gaseous, are non-flammable irrelevant of their concentration in air.
- Refrigerants with a time-weighted, averaged concentration that have no adverse effects on the majority of staff that are exposed every day during a normal 8 hour working day and a 40 hour working week to this concentration, which is greater than or equal to 400 ml/m^3 (400 ppm (V/V)).



There is no imminent danger for the staff. However, refrigerants of the Group L1/A1 are generally heavier than air and may flow off to rooms on a lower level. In still air there may be an increase of the ground level concentration. With high concentrations there is a danger of suffering from disordered cardiac rhythm and suffocation due to a reduced oxygen concentration, especially at ground level.

Unauthorised people must not have access to the unit. Please ensure that CFC/HFC refrigerant escaping from the unit cannot reach the interior of the building or put people at risk in any other way.

Comply with the requirements of EN 378-3 for refrigerants, filling weight and cold transfer systems.

Install the unit in accordance with EN 378-1 only in the commissioned configuration and only in a set-up room that the unit manufacturer has configured the unit for.

Install the unit in accordance with EN 378-3, section 5 in a special machine room if an explosion or a CFC/HFC refrigerant concentration of more than that permissible under EN 378-3 could endanger the work environment. Take effective protective precautions if such a spatial separation were to be required, but is not possible.

Install the electrical equipment (for fan operation, for ventilation, for lighting and for the alarm system) in the set-up room while observing the condensing-out of moisture and drip water formation, as well as the risk level of CFC/HFC refrigerant in accordance with EN 378-3; section 6.

Arrange CFC/HFC refrigerant detectors and alarm systems to warn of explosion or fire dangers and CFC/HFC refrigerant concentrations that are hazardous to health

and for control purposes in the unit set-up room in accordance with EN 378-3; section 7.

Ensure that the device in the set-up room is not exposed to any inadmissible high temperature effects. Effectively protect the unit against heat sources or temporary high temperatures.

⚠ WARNING

Danger of environmental pollution!

- Ensure that no refrigerant enters water systems or sewage.
- Operate the facility for recovering or disposing of refrigerant so that the danger of a refrigerant or refrigerator oil emission into the environment is kept as low as possible.

7.2 Requirements at the set-up point

You will find the dimensions and weights in the order-related documents.

- ▶ Position the unit so that it cannot be damaged by internal traffic or transport processes.
- ▶ Ensure that the unit is a sufficient distance from the walls in order to ensure adequate ventilation:

Minimum distance A:

GACA 040: A = 500 mm

GACA 045: A = 550 mm

GACA 050: A = 600 mm

GACA 063: A = 730 mm

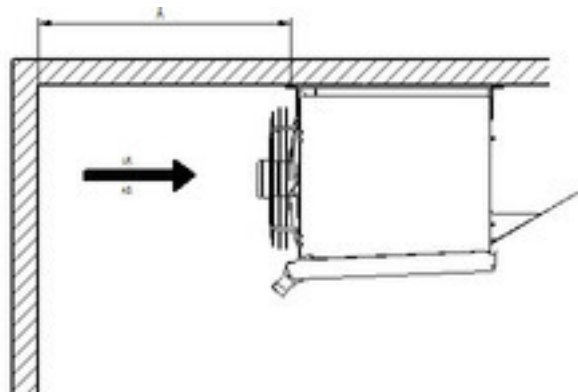

Minimum distance N:

GACA 040: N = 700 mm

GACA 045: N = 800 mm

GACA 050: N = 800 mm

GACA 063: N = 900 mm

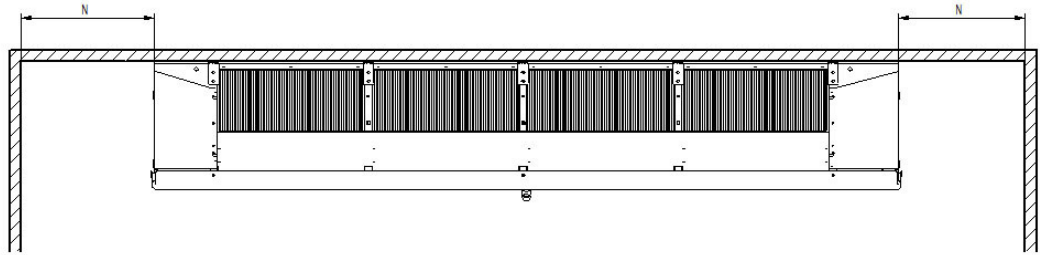

NOTICE

The minimum distances A and N are calculated to provide sufficient ventilation. They do not take into account the clearances required for the installation or when replacing heating rods!

- ▶ Enable optimum unit control and accessibility:
 - Place the unit so that it can be monitored and controlled from all sides at all times.
 - Ensure that sufficient space is provided for maintenance.
 - Ensure that all liquid-carrying components, connections and lines and all electrical connections and lines are easy to access.
 - Ensure that there is free space for the unobstructed installation and exchange of heater rods for electric defrosting (selection option) .
 - Ensure that the pipes' identification is well visible.
 - Ensure that the free space in front of and beside the unit (e.g. the distance from the unit to any possible obstructions) is big enough that the easy to open side covers and the removable and hinged drip trays can be accessed hazard and obstruction-free.

7.3 Unpacking the unit

Wooden packaging

The units are delivered in their mounting position in wooden crates. The units are placed on transport feet to relieve load on the drip tray. The unmounted air guiding sheet is behind the unit and is fastened to the wooden packaging. The brackets for attaching the air guiding sheet are fastened to the wooden packaging next to the fans. The screws required for mounting the air guiding sheet are also supplied. The unmounted drip tray is behind the unit. When a number of units are delivered together, up to three wooden crates may be stacked on top of one another.

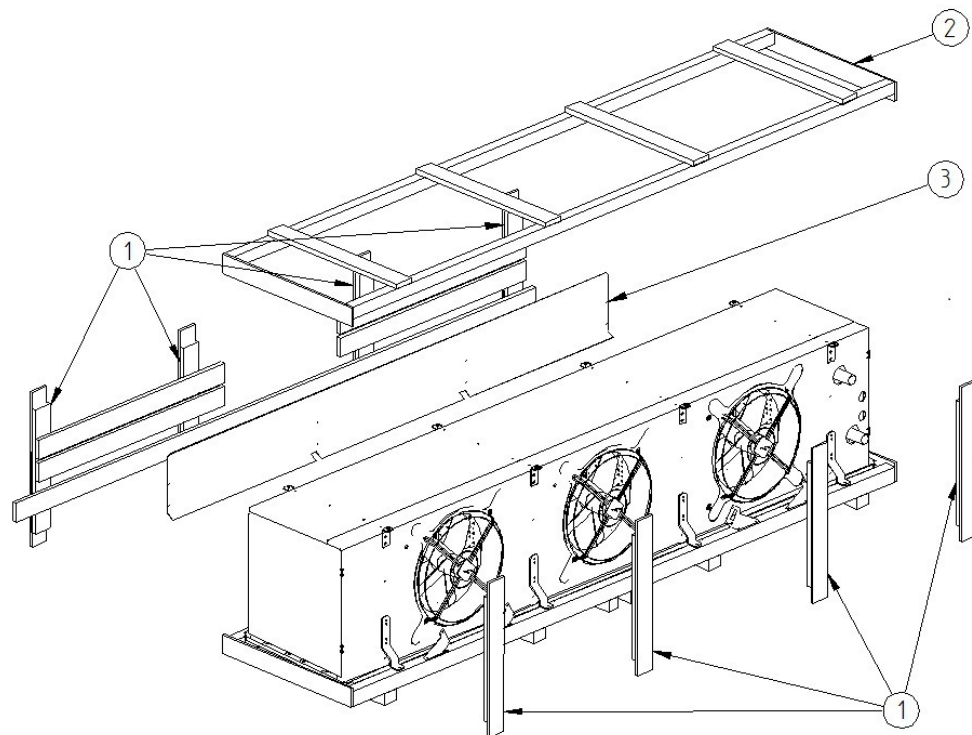

- ▶ When a number of units are delivered: Place the crates individually on the ground.
- ▶ Remove the pieces of wood at the sides (1) and top (2). Leave the unit on its transporter.
- ▶ Unfasten the air guiding sheet (3) and set it aside.
- ▶ Unfasten the brackets for the air guiding sheet from beside the fans and set them aside.
- ▶ Check the delivery for completeness. You will find a list of the contents of the package in the order-related documents.
- ▶ Any transport damage and/or missing parts must be recorded on the bill of delivery. The facts must be immediately reported to the manufacturer in writing. Damaged fins can be straightened on-site with a fin comb.

The following applies to all units:

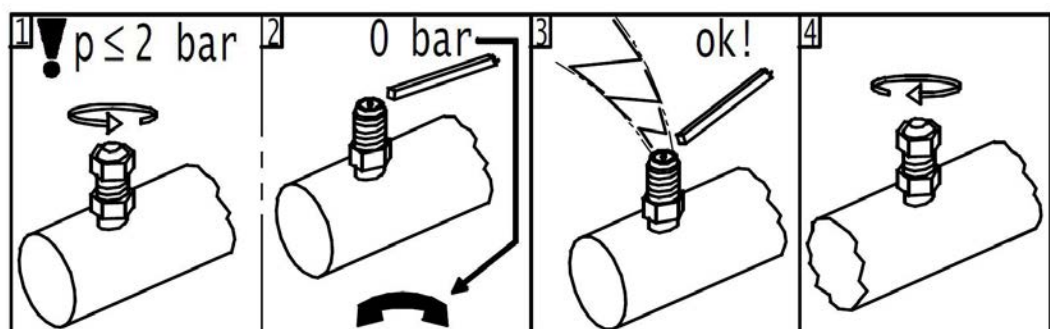

- ▶ (1) Screw off the cap.
- ▶ (2) Check the transport overpressure: The units are delivered from the manufacturer with approx. 1 bar transport overpressure (cleaned and dried air). Read off the transport pressure on

the Schrader valve (pressure measurement). With unpressurised unit: Immediate report to manufacturer and noting on bill of delivery.

⚠ CAUTION

Danger of injuries and damage to property with escaping working fluid!

An unpressurised unit indicates a leak due to transport damage. Escaping working fluid from leaks in the unit can cause injuries and damage to property. [Residual hazards due to CFC/HFC refrigerants](#)
Do not put the unit into operation!

- ▶ (3) Release the transport overpressure (only do this immediately before the installation).
- ▶ (4) Replace the cap and screw it tight.

NOTICE

Danger of corrosion and dirt build-up!

Moisture and dirt must be prevented from entering the unit.

Protect the unit against dust, dirt, moisture and wetness, damage and other harmful effects. Harmful effects: [see Safety instructions for set-up and start-up, page 35](#)

Begin with the installation as soon as possible.

7.4 Installation

7.4.1 System-side requirements for stress-free installation

- ▶ Prevent stresses in the unit:
 - Ensure that all fixing points have the same spacing to the fixing level.
 - Ensure that all fixing points maintain the same spacing to the fixing level under load and permanently.
- ▶ Set up and fix units as follows: Airflow must not be impaired by obstructions.
- ▶ The units must be installed on fixing points that are appropriate for the unit's weight and then bolted with fixing bolts. The operator or installer of the equipment is responsible for ensuring that the bolted connections are of an adequate strength. The following instructions must be observed when fixing the units:
 - The diameter of the mounting holes have been statically determined by the manufacturer; the fixing bolts must be adapted accordingly. When calculating the transferring bearing strength it is imperative to take into account the total weight of the unit (= structural weight + weight of pipe content + additional weight, such as water, frost, ice, dirt or similar).
 - The fixing bolts must be secured against loosening with an appropriate locking device.
 - The fixing bolts must not be overtightened or stripped.
 - All fixing bolts must be tightened equally.
- ▶ Prevent the unit from shifting in its position. Fix the unit in its position. Tighten the fixing bolts and secure then against loosening.
- ▶ Only fix the unit to the intended fixing points.

7.4.2 Mounting the unit

7.5 Notes on connecting the unit

WARNING

Danger of injuries and damage to property with escaping CFC/HFC refrigerant!

Incorrect installation risks working fluid escaping when the unit is operated, causing injuries or damage to property (see [Residual hazards due to CFC/HFC refrigerants](#) , page 23).

Prevent working fluid from escaping from the unit into the environment.

- Secure all working fluid-carrying lines against mechanical damage.
- In areas that are used for internal traffic, only lay the pipelines to and from the unit with connections and fittings that cannot be removed.

Ensure that the on-site connections do not exercise any forces upon the distribution and header points. This can cause leaks on the working fluid connection points of the unit and on connection points of the on-site pipe-laying.

NOTICE

NEVER use pliers on the drip tray drain! Tighten it by hand!

7.5.1 Connecting the drain line to the drip tray

Please observe the following instructions with the installation:

- ▶ Lay drain line completely strain-free. The diameter of the drip water drain line must be at least that of the drip water drain of the unit, and the drip water drain line should be laid with a slope (3 – 5°).
- ▶ Tighten connection nuts with the hand only!

NOTICE

Danger of damaging! The plastic threads can be damaged by over-tightening if you use a wrench. This results in leaks with drip water damage on the produce to be cooled. Do not tighten the connection nuts with a wrench!

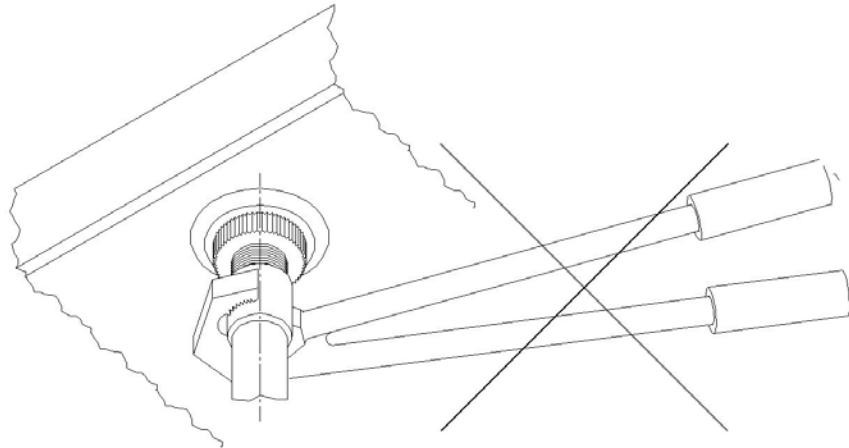

7.5.2 Connect the unit to the system

⚠ WARNING

Danger of injuries and damage to property!

Improper connection to the the system causes hazards:

- Leaks result in escaping CFC/HFC refrigerant ([see Residual hazards due to CFC/HFC refrigerants, page 23](#)).
 - Soldering and welding work on pressurised parts can result in fires or explosions.
 - Smoking or open light can cause fires due to the presence of refrigerator oil.
 - Ensure that stresses and vibrations from the system are not passed on to the unit.
 - Only lay working fluid-side connections stress-free! The on-site pipeline system must be braced before connecting to the unit!
 - Soldering and welding work is only permitted on unpressurised units!
 - The use of open fire at the installation site is forbidden. Fire extinguishers and extinguishing agents used to protect the equipment and the operating staff must comply with the requirements of EN 378-3.
 - Ensure that refrigerant detectors and alarm systems for warning about fire dangers, about health-endangering concentrations and for control purposes at the unit set-up point are arranged in acc. with EN 378-3; section 7.
- Install the pipes in acc. with EN 378-1 and EN 378-3. Ensure here:
- That the connections are easy to access with the hinged side panels.
 - Release devices to prevent liquid escapes must be provided and available.
 - That in shutdown state under-cooled liquid is only present in the lowest possible amount in system sections – minimized number of "fluid sacks".

- That the pipeline installation is kept as short as possible. Use as few bends as possible, and if bends are necessary, use big radii!
- Avoid transmitting vibrations to the unit via conduits or pipes. If necessary, use vibration dampers.

7.5.3 Unit electrical connection and protection

- ▶ Connect fan motors in acc. with motor connection circuit and check connection.
- ▶ Provide power supply in acc. with the specifications on the fan motor's type plate:
- ▶ Connect thermo contacts for motor protection.
- ▶ Seal all electrical lines to the connection boxes in acc. with their protection class. The connection class is specified in the order-related offer documents.

WARNING

Danger of damaging! If the fuse rating is too high there is the danger of injuries to people and damage to property.

The supply lines must always be fused as appropriate for the smallest wire cross-section.

7.6 Perform acceptance test

WARNING

Danger of injuries and damage to property!

Escaping CFC/HFC refrigerant can cause injuries or even death ([see Residual hazards due to CFC/HFC refrigerants, page 23](#)).

Perform the following acceptance test with an expert before starting up the unit after making important changes and after a unit exchange.

- ▶ Ensure that the temperature and air humidity at the set-up point are in line with the technical data ([see Technical data, page 29](#)).
- ▶ Ensure that sufficient air can be sucked in and released.
- ▶ Ensure that the supply feed is sufficient for the required energy. Compare the unit inside of the system with the plans of the system and the electrical wiring diagrams.
- ▶ Test the unit for vibrations and movements that can be caused by the fans and operation of the system. Remove oscillations, vibrations and movements following consultation with the manufacturer or independently.
- ▶ Perform visual inspection of the structural design, the brackets and fixtures (materials, sequence, connections), the ability to operate and the arrangement of the fittings.
- ▶ Check that the tray installation with safety catch is correct.
- ▶ Check and if necessary re-tighten all threaded connections, especially on the fans.
- ▶ Check installation of pipe connections.
- ▶ Check laying of working fluid-carrying connection pipes.
- ▶ Ensure that the unit is protected against mechanical damage.
- ▶ Ensure that the unit is protected against inadmissible heating up and cooling down.
- ▶ Check the fan blades protection.

- ▶ Ensure that optimum unit control and accessibility are guaranteed.
 - Is the unit placed so that it can be monitored and controlled from all sides at all times?
 - Is sufficient space provided for maintenance?
 - Are all liquid-carrying components, connections and lines and all electrical connections and lines easy to access?
 - Are the pipes easy to identify?
- ▶ Check heat exchanger surfaces for dirt and clean as required ([see Clean unit, page 55](#)).
- ▶ Perform function tests on the fans (rotation direction, power consumption, etc.).
- ▶ Check the soldering and welding connections, the electrical connections and the fixture connections.
- ▶ Perform pressure test with test gas and with a test pressure of 1.1-times the permissible operating pressure: check the connection seals and detect leaks, e.g. with foaming agent, or similar.
- ▶ Check corrosion protection: Perform a visual inspection on all bends, components and component holders that are not heat-insulated. Document and archive test results.
- ▶ Perform test run. Observe and check unit during test run, in particular for:
 - Fan smooth running (bearing noises, contact noises, imbalances, etc.).
 - Fan power consumption:
 - Leaks
- ▶ Report all defects to the manufacturer immediately. Remove defects following consultation with the manufacturer.
- ▶ Check the unit and the unit's interaction with of the system again after 48 operating hours, especially on the connections and on the fans, and document the test results.

7.7 Test readiness for operation

- ▶ Ensure that all electrical protective measures are ready to function.
- ▶ Ensure that all working fluid-carrying connections are securely in place.
- ▶ Ensure that all electrical connections (fans) are effected securely.
- ▶ Ensure that all threaded connections on the fans, the unit fixing bolts and all other threaded connections are firmly tightened.

7.8 Putting the unit into operation for the first time

WARNING

Danger of injuries and damage to property!

Escaping CFC/HFC refrigerant can cause injuries or even death ([see Residual hazards due to CFC/HFC refrigerants, page 23](#)).

You can put the unit into operation, only when:

- The unit has been properly mounted and connected ([see Installation, page 41](#)).
- You have performed a complete acceptance test ([see Perform acceptance test, page 44](#)).

- You have checked the unit's readiness for operation (see [Test readiness for operation, page 45](#)).
- All safety precautions (see [Safety, page 35](#)) have been taken.

Follow the operating instructions manual of the system!

Contact the manufacturer immediately if you want to operate the unit under different operating conditions as those defined in the order-related offer documents.

- ▶ Switch on the system including of the electrical system (see system).
- ▶ Activate the unit:
 - Open the valves on the inlet and outlet-side system.
 - Activate fans
- ▶ Wait until the operating point is reached. After the operating point is reached the unit is ready to operate (see system).

Parameters for setting the operating point, see order-related offer documents.

Operating point:

- Airflow volume
- Air inlet temperature

To ensure the specified operating point is complied with the actuators for the operating point setting must be secured against unauthorized access (e.g. by sealing, screwing on caps, removing hand wheels, etc.).

8 Operation

8.1 Safety

WARNING

Danger of cutting off, pulling in!



There is a danger of cutting off fingers on the rotating fan blades, injury hazard for the hands and pulling in danger with loose elements such as hair, necklaces or clothing parts.

Do not operate fans without guard grille!

8.2 Putting the unit into operation

- ▶ Switch on electrical system
- ▶ Open working fluid-carrying lines
- ▶ Switch on fans

8.3 Taking the unit out of operation

- ▶ Switch fans off
- ▶ Switch electrical system off
- ▶ Close working fluid-carrying lines
- ▶ **NOTE! When shut down consider max. operating pressure! If necessary, take precautions to ensure that it cannot be exceeded, or drain the device.**

NOTICE

With shutdown times of a month or longer put the fans into operation for approx. 2-4 hours a month to maintain their functionality.

8.4 Shutting the unit down

WARNING

Danger of injuries and damage to property!

Escaping CFC/HFC refrigerant can cause injuries ([see Residual hazards due to CFC/HFC refrigerants, page 23](#), and [see Residual hazards caused by pressurised parts, page 25](#)).

Ensure that the maximum operating pressure is not exceeded after the shutdown either!

NOTICE

Danger of corrosion and dirt build-up!

Moisture and dirt must be prevented from entering the unit.

Protect the unit against dust, contamination, moisture and wetness, damage and other harmful influences (see [Safety instructions for set-up and start-up, page 35](#)).

With shutdown times of a month or longer put the fans into operation for approx. 2-4 hours a month to maintain their functionality.

- ▶ Take the unit out of operation (see [Taking the unit out of operation, page 47](#)).
- ▶ Secure the unit:
 - When shutdown consider max. operating pressure (see [Technical data, page 29](#))! If necessary, take precautions so that it cannot be exceeded.
 - Secure working fluid-carrying lines against pressurizing with working fluid.
 - Protect against damaging effects at the set-up point or intermediate storage location (see [Safety instructions for set-up and start-up, page 35](#)), so that the unit's components are kept properly looked after and the proper intentional use and usability of the unit are maintained. The corresponding storage conditions must be provided for this (see [Storage before installation, page 34](#)); precautionary corrosion protection measures, regular checking of the fans' functionality and regular checks on the shutdown unit.
- ▶ Evacuate the unit: Completely release working fluid and, if applicable, refrigerator oil (see [Residual hazards with disposal, page 27](#)).

8.5 Putting the unit into operation after a shutdown

The unit must be put back into operation after a shutdown in acc. with the system-specific set-up in acc. with the operating instructions manual as follows:

- ▶ Test the unit's readiness for operation (see [Test readiness for operation, page 45](#)). Perform pressure test and visual inspection for corrosion protection.

NOTE! The pressure test with recommissioning must only be carried out with appropriate media at appropriate test pressure.
- ▶ Put the unit into operation (see [Putting the unit into operation, page 47](#)).

8.6 Changing the unit over to another working fluid

⚠ WARNING

Danger of injuries and damage to property!

Considerable dangers can be caused with operation with another working fluid without prior manufacturer approval (see [Improper use, page 19](#)).

Without prior written consent from Guntner GmbH & Co. KG, the unit must not be changed over to use a different working fluid.

- ▶ Ensure that the unit manufacturer has agreed to the changeover.
- ▶ Ensure that the right working fluid is re-filled. Ensure that all materials used in the unit are compatible with the new working fluid.
- ▶ Ensure that the permissible pressure is not exceeded.

- ▶ Check that the new working fluid can be used without requiring a new test certificate for the unit. Ensure that classification is complied with.
- ▶ The safety device for the unit must be swapped out or reset.
- ▶ Mixtures with residues of working fluid and oil, for example, must be prevented.
- ▶ All information concerning the new working fluid must be changed accordingly.
- ▶ The complete documentation, including these operating instructions and the system operating instructions manual must be changed accordingly.
- ▶ Perform acceptance test ([see Perform acceptance test, page 44](#)).

9 Troubleshooting

9.1 Safety

⚠ WARNING

Danger of injuries and damage to property!

Faults that are not described in these operating instructions may be resolved only by GÜntner. Contact the GÜntner hotline.

Faults that are described in these operating instructions must only be removed by appropriately trained personnel ([see Personnel, care requirements, page 17](#)).

If any faults occur during the operation, monitoring or maintenance of the system as a whole, inform GÜntner GmbH & Co. KG immediately.

9.2 Service

Office hours

Tel. +49 8141 242-473

Fax. +49 8141 242-422

Email: service@guentner.de

Mon-Thurs: 7.30 am - 5 pm

Fri: 7.30 am - 1.30 pm

9.3 Troubleshooting table

Fault	Possible cause(s)	Remedy
Fan motor not running	Power supply interrupted	Restore power supply
	Fan blade stuck	Enable fan to rotate freely
Bearing noises	Defective fan motor	Renew bearing or fan motor
Unit vibrating	Defective fan blades	Change fan blades
	Loose fan fixture	Tighten fixtures
Unit capacity not achieved	Heat exchanger is very dirty on the air side	Clean
	Fans not running properly or down	Repair, exchange fans
	Working fluid pressurising defective (temperature and quantity insufficient)	Set working fluid pressurising values (temperature and quantity) to reference values.
Working fluid escaping	Unit working fluid-carrying components leaking	Switch off working fluid feed and fans, close leak

9.4 Dealing with faults

- ▶ Try to determine the size of the leak.
- ▶ If the room can be entered with a protective device for the respiratory system,
 - provide emergency ventilation before entering the room
 - shut off refrigerant feed
- ▶ With the tiniest suspicion of injured people in the area, sound the alarm. First get people to safety, then remove leaks. Close all doors to the room in which the is escaping.
- ▶ Activate Emergency STOP switch. Valves, motors and other components are therefore switched off to prevent from escaping.
- ▶ Close shut-off valves, especially to the liquid side, where possible in sections, so that the quantity in the leakage area is kept as low as possible. If possible evacuate/drain the systemssection in question and to other systems sections.

10 Maintenance

10.1 Safety

10.1.1 Before starting all maintenance

WARNING

Danger of injuries and damage to property with escaping working fluid! [see Residual hazards due to CFC/HFC refrigerants , page 23](#)).

Only perform maintenance work – especially welding work – on the leaking unit after completely removing the working fluid from the leaking unit!

Perform the following safety measures before beginning all maintenance work:

- drain the unit's heat exchanger
- Clean and blow out the unit's heat exchanger.

10.1.2 With all maintenance work

WARNING

Danger of injuries and damage to property with escaping CFC/HFC refrigerant!

Escaping refrigerant with leaks on the evaporator can cause the following hazard situations and injuries:



Warns against cold!

Still present CFC/HFC refrigerant under defervescence has a temperature of 0 °C. Contact with refrigerant under defervescence caused by spraying causes frostbite.



- Use eye protection!



- Use hand protection!

- Ensure that the unit in question is pressure-free before maintenance work begins or the working fluid is sucked up from the unit in question.
- Power off the electrical system and secure it against unintentional switching on again.
- Separate the unit to be maintained from the refrigeration system and secure it.

NOTICE



Danger of damage to property!

With work in the inlet and outlet feeds of the fans and heat exchanger, objects can get into the fans and therefore cause faults and damage on the components.

10.1.3 After all maintenance work

⚠ WARNING

Danger of injuries and damage to property with escaping CFC/HFC refrigerant! [see Residual hazards due to CFC/HFC refrigerants , page 23](#)!

Perform the following safety measures after finishing all maintenance work:

- Ensure the switching and activation devices, the measuring and display devices and the safety devices function properly.
- Ensure the working fluid fittings are functioning.
- Check the identification of the pipelines and ensure this is visible and legible.
- Check the fixing and corrosion protection of the components in question.
- Ensure the electrical connections (e.g. fans) are functioning.
- Perform a pressure test and a tightness test (see operating instructions manual annex).
- Perform an acceptance test ([see Perform acceptance test, page 44](#)).
- Perform a pressure test (see operating instructions manual annex).

10.2 Inspection and maintenance plan

Regular checks of all the safety-related parts of the system are an essential part of fulfilling all requirements. Repeated tests must be performed either by a “qualified person” as defined in § 2, section 7 of the German Ordinance on Industrial Safety and Health (BetrSichV), or by a certified inspection agency. The operator must determine the test intervals for the complete system and the system components on the basis of a safety-related evaluation. Nevertheless, as with every technical installation, whereby it can generally be said the most frequent causes are not material errors, but operating errors, certain incidents cannot be ruled out.

The checks to be performed are listed in the following sections as time-scaled checklists.

10.2.1 Fans

The manufacturer’s operating specifications take priority for this component. Güntner GmbH & Co. KG recommends proceeding according to the following inspection and maintenance plan:

d = daily, w = weekly, m = monthly, y = yearly				
Work to be performed	d	w	m	y
Check the fan drive for smooth running. <ul style="list-style-type: none"> • Vibrations on the unit: remove imbalances • Where required, tighten and correct blade fixtures and blade settings 				X *



d = daily, w = weekly, m = monthly, y = yearly				
Work to be performed	d	w	m	y
Fan bearing: Running sound and smoothness changes • Exchange bearing				X *
Fan motor: Is a new bearing due? • Exchange bearing or motor; where applicable, clean and repair motor				X *
Fan wheel: corrosion on bolts (with threaded blades) • exchange bolts				X *
Fan blades: Corrosion or damage on blades • Exchange blades or wheel				X *

*) Recommended: every six months

10.2.2 Unit heat exchanger

WARNING

Danger of injuries and damage to property with escaping CFC/HFC refrigerant! [see Residual hazards due to CFC/HFC refrigerants , page 23!](#)

Care and maintenance plan

Measure	Cleaning agent	Interval
Remove frost and clean component	Mechanically	according to requirements (visual examination)
Defrosting of the heat exchanger unit	Circulation air, electric; automatic defrosting device...	According to local conditions (stress due to penetrating moisture from e.g. air or chilled goods), at the latest which the ice is 1 mm thick.
Complete cleaning	Warm water and/or environmentally safe cleaning agent	As required (recommended every six months)
Leak check		After 6 months
Corrosion protection check		After 6 months

10.3 Maintenance work

10.3.1 Remove leaks

⚠ WARNING

Danger of injuries and damage to property with CFC/HFC refrigerant ([see Residual hazards due to CFC/HFC refrigerants , page 23](#))!

- Have leaks removed as quickly as possible by an expert.
 - Do not fill with a working fluid other than that specified in acc. with the order-related offer documents!
 - Only put the unit back into operation when all leaks have been repaired.
- ▶ Perform all work including pressure, acceptance and functional test ([see Perform acceptance test, page 44](#), and [see Test readiness for operation, page 45](#)).

10.4 Clean unit

10.4.1 General

The following applies for cleaning: The operator must ensure that the cleaning agents are environmental friendly and compatible for the materials in the system. Harmful to the environment substances, e.g. acid-forming, are forbidden.

ACHTUNG - ATTENTION - ATTENTION - ATENCIÓN

Bei der Verwendung von Reinigungsmitteln in Kühlräumen, ist auf die Korrosionsbeständigkeit der Materialien des Kühlers gegenüber dem verwendeten Reinigungsmittel zu achten!	When cleaning agents are used inside the cold room, the corrosion resistance of the cooler materials to the applied cleaning agent has to be observed!	Lors de l'utilisation des détergents dans les chambres froides, il faut observer à la résistance à la corrosion des matériaux de l'appareil qui entrent en contact direct avec les détergents.	Cuando se apliquen agentes limpiadores en los productos instalados en cámaras frías, se debe tener cuidado que no corroen los materiales usados para la construcción del producto!
---	--	--	--

- ▶ Clean casing by rinsing with warm water (approx. +25°C) and/or with environmentally friendly cleaning agents.
- ▶ Rinse thoroughly with water after using cleaning agents.
- ▶ Allow casing to dry completely.
- ▶ Check working fluid-side and electrical connections ([see Test readiness for operation, page 45](#)).

10.4.2 Removing the drip tray and side cover

The drip tray and the side cover can be removed for cleaning and maintenance purposes. The drip tray has a safety catch, which must be removed for this.

Removing the drip tray

- ▶ Unscrew the drip tray drain by hand. Do not use pliers!

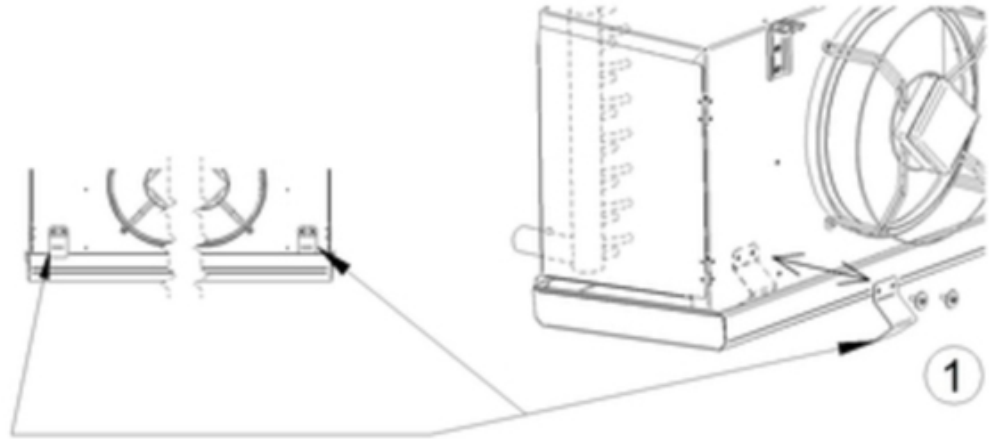

- ▶ Loosen the screws securing the drip tray support bracket (1). Remove the drip tray support bracket.

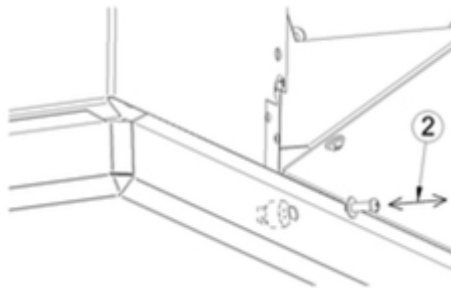

- ▶ Loosen and remove the drip tray screws (2).

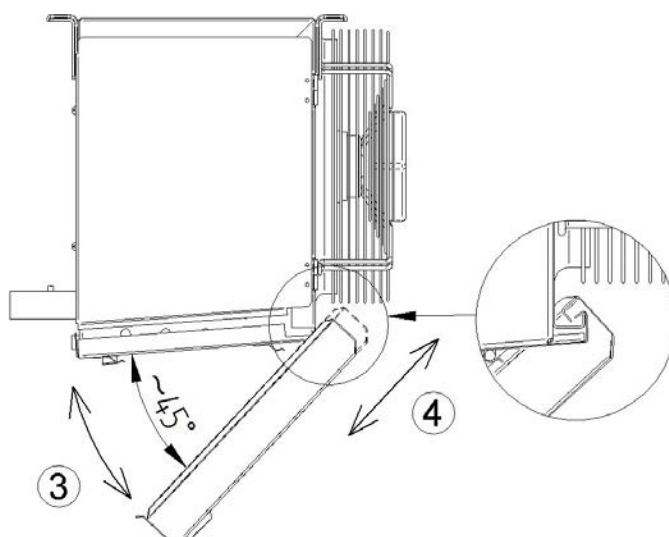

- ▶ Open up the tray to an angle of 45° (3).
- ▶ Lift up the drip tray from the edge of the fan plate (4).

Removing the side cover

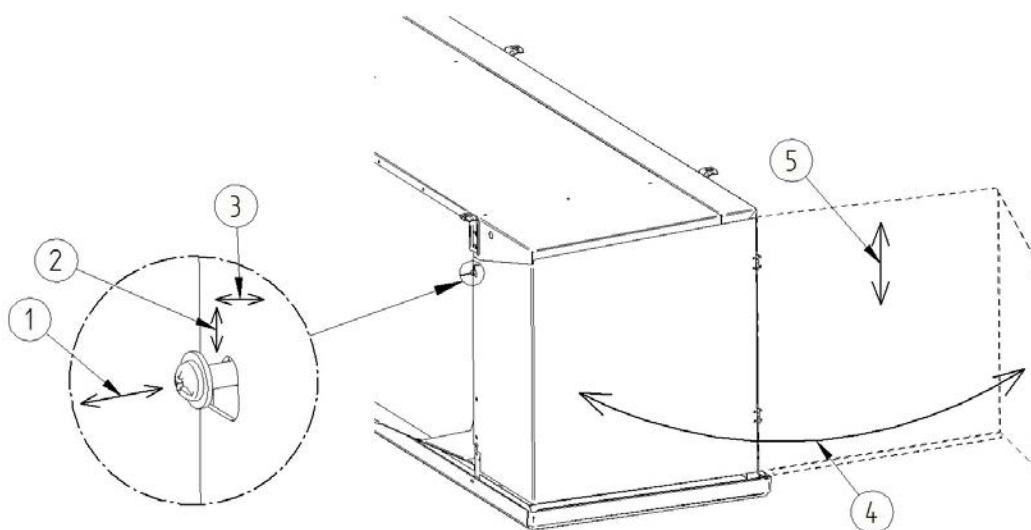

- ▶ Loosen the screws by about 5 mm (1). DO NOT remove them!
- ▶ Slightly lift up the side cover (2).
- ▶ Pull the side cover over the screw (3).
- ▶ Swivel the side cover to the side (4).
- ▶ Lift up the side cover (5) and remove it from the unit.

10.4.3 Clean heat exchanger

- ▶ Drain the unit (see system).
- ▶ Shut off the unit (see system).
- ▶ Power off the fans (see system).
- ▶ Clean the heat exchanger with one of the following procedures:
 - Cleaning with compressed air ([see Cleaning with compressed air, page 58](#)).
 - Hydraulic cleaning ([see Hydraulic cleaning, page 58](#)).

NOTICE

Danger of damage to property!

The fins can be damaged with too high a pressure, too small a distance or a cleaning jet that hits the fins at an angle. Mechanical cleaning with hard objects (e.g. steel brushes, screw drivers, or similar) damages the heat exchanger.

- Use a pressure of max. 50 bar with hydraulic cleaning and max. 80 bar with cleaning with compressed air!
 - Maintain a minimum distance from the fins of 200 mm!
 - Always aim the jet vertically (max. ± 5 degree deviation) at the fins!
 - Do not use any hard objects when cleaning!
- ▶ Switch fans on (see system).

10.4.3.1 Cleaning with compressed air

- ▶ Blast heat exchanger (max. 80 bar pressure) with compressed air to remove dirt and contaminants.

NOTE! Hold the jet of the cleaner vertical to the fins (max. deviation of ± 5 degrees) to prevent fins from bending.

10.4.3.2 Hydraulic cleaning

⚠ WARNING



Warns against dangerous electrical voltage!

Direct and indirect contact with voltage-carrying parts of motors and electrical lines can cause serious injuries or death. Water and cleaning agents conduct electricity.

- Power off the fans for cleaning with water or steam jet and ensure them against switching on again.

NOTICE

Danger of damage to property!

Water or steam jets can damage fans, electrical lines or other components.

- Ensure that electrical connections and motors, as well as components and stored goods at the set-up point are not touched by water or steam jets. Cover these if required.
- ▶ Heavier moisture or greasy dirt must be removed with a high-pressure water jet (max. 50 bar pressure), steam pressure jet (max. 50 bar pressure), min. 200 mm distance with flat jet nozzle,

or using neutral cleaning agent where applicable, always against the airflow direction. Ensure here:

- With oily and greasy dirt it helps to add a cleaning agent to the water.
- When applying chemical agents ensure that they are not aggressive towards the unit's materials. Rinse the unit off after the treatment.
- Cleaning should be done from inside to the outside (but always opposing the dirt onset) and from top to bottom, so that the dirt can be removed without returning.
- Hold the jet of the cleaner vertical to the fins (heat exchanger – max. deviation of ± 5 degrees) to prevent fins from bending.

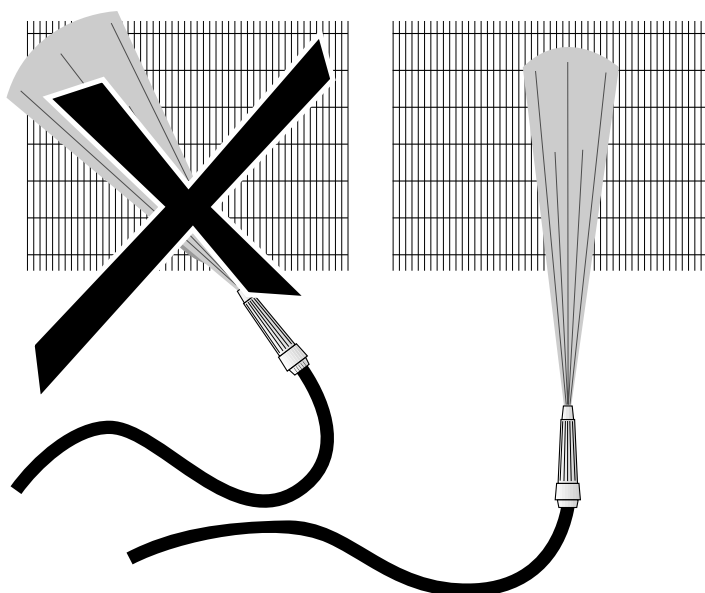

- ▶ Continue cleaning until all dirt has been removed.

10.4.4 Cleaning fans

⚠ WARNING

Danger of cutting off, pulling in!

There is a danger of cutting off fingers on the rotating fan blades, injury hazard for the hands and pulling in danger for loose elements such as hair, necklaces or clothing parts.

- Power off the unit before you begin maintenance work. Secure the unit against unintentional switching on again by removing the electric fuses for the unit. Secure the unit with a suitable warning sign referring to unintentional switching on.
- Put fans and guard grilles that were removed or opened for maintenance back into their original status without fail before you put the unit back into operation!

Dirt build-ups on the fans and the fan guard grilles must be removed regularly, otherwise they will cause imbalances or destruction and power losses. The fan motors themselves are maintenance-free.

- ▶ Power off the unit and secure it against unintentional switching on.
- ▶ Clean fans with one of the following procedures:
 - NOTE! Danger of damage to property! Mechanical cleaning with hard objects (e.g. steel brushes, screw drivers, or similar) damages the fan. Forbidden!**
 - Cleaning with compressed air: Blow fans with compressed air (max. 10 bar pressure; min. distance 200 mm) to remove dirt and contaminants. Continue cleaning until all dirt has been removed.
 - Cleaning with compressed air and brushes: Remove dry dust or dirt with a brush, a hand brush or with compressed air (max. 10 bar pressure, min. distance of 200 mm) or with a powerful industrial vacuum cleaner. Ensure here: use soft brushes (no steel brushes or similar)! Continue cleaning until all dirt has been removed.
- ▶ Mount guard grille
- ▶ Switch unit on

10.5 Defrosting the unit

10.5.1 Notes on defrosting

⚠ WARNING

Warning against personal injury and damage to property!

Danger of falling unit parts, masses of water or ice when the drip tray is flapped out.

Nobody is allowed to be in the danger area below the unit during cleaning or maintenance work. The drip tray can be flapped down for cleaning and is protected from falling down by a safety catch. Unit parts, masses of water or ice can nonetheless fall down when it is flapped down.

Defrosting the unit at the correct times guarantees continuous operational reliability and the prevention of inaccessibilities that could result in a shutdown and disruptions. As the local conditions have a very big influence of the unit's performance and the need for defrosting, the operation must be checked regularly and specifically for frost and/or icing on the heat exchanger. The following notes apply for defrosting the unit:

- Regularly check for frost and/or icing. With a frost thickness of max. 1 mm per fin side the unit must be defrosted to be able to guarantee fault-free operation.
- Defrosting process must start in good time.

The defrosting frequency depends on the effects of penetrating moisture (e.g. cold storage room door) or introduced moisture (e.g. , .). It must be noted here that the temperature difference between the working fluid and the air inlet temperature is critical for the defrosting frequency:

- Unit with greater temperature difference: Frequent defrosting
- Unit with lesser temperature difference: Less defrosting

Alternating operating states, e.g. usage changes at the set-up point, must also be considered. The defrosting frequency can be influenced by effects on the air side. Insufficient unit-wall distance, distance between two opposing units too low, underdraughts shortly before the air outlet cause increased defrosting frequency.

Defrosting completeness

When finishing the defrosting process you must ensure that the defrosting is absolutely complete. Selecting the right defrosting temperature is an important requirement in this respect.

- If the defrosting temperature is set too low this impairs the unit's effectiveness from one defrosting to another with the removal of "ice-spots".
- If the defrosting temperature is set too high this causes extreme water vapour formation, which causes frost and ice to form around the unit.

Settling time

A period (approx. 5 to 8 minutes) between when the defrosting finishes and when the unit is activated has been proven to be necessary, as the unit's heat exchanger can drip off completely and the defrosting water can flow away through the drip water tray drain during this period.

Delayed fan start

If the fans' activation is delayed by a further period (approx. 3 to 5 minutes), then the defrosting heat from the heat exchanger is absorbed and it is not given off into the room as warm-moist air.

10.5.2 Defrost control

- The defrosting process is started at pre-set intervals or as required.
- The process completion must be ensured twice (time/temperature and temperature/temperature),
- For defrost operation (circulation air, electric) the correct on-site installation of the defrosting sensor must be ensured. See defrosting procedure listed below.
- Recommendation – perform the defrosting process at the following times:

Electric defrosting (optional)

Cold operation	X					
Suction operation		X				
Defrost operation			X			
Drip phase				X		
Freeze on phase					X	
Cold operation						X
Fans	Operation	Operation	Off	Off	Off	Operation

The duration of the individual phases depends from a variety of factors (e.g. temperature, moisture, etc.) in the particular application.

10.5.3 Circulation air defrosting

With operation of the units at room temperatures in the plus range (plus-cold storage rooms) and evaporation temperatures $t_0 = 0$ to -5°C , circulation air defrosting is usually sufficient: with shut-off working fluid-carrying lines the required defrosting heat is generated by the fan heat flow and the air temperature in the plus range. But it also applies here: the refrigerating operation may be restarted, as described, only after complete defrosting.

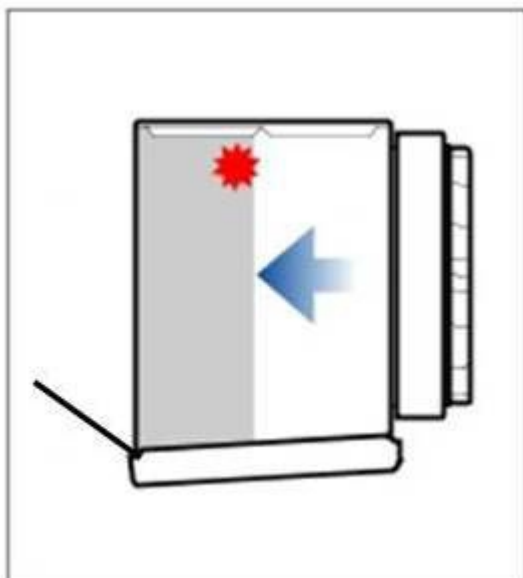

10.5.4 Electric defrosting

The following must be ensured here: With alternating defrosting within a room (group defrosting), use defrost closure devices (defrost flaps, textile closure devices)! An on-site monitoring with a safety device (temperature limiter; to be planned for in creating the annex) must be provided in acc. with EN 60519-2; VDE 0721; T. 411 to rule out the danger of the units overheating. Operation without a temperature monitor is forbidden! The max. permissible fuse for the electric heating groups

with 20 A must be complied with without fail. The min. fusing is provided in the order-related connection diagrams. To prevent the permissible pressure in the unit from being exceeded with electric defrosting systems, in acc. with EN 378-2 either working fluid displacement must be enabled or a suction circuit must be provided.

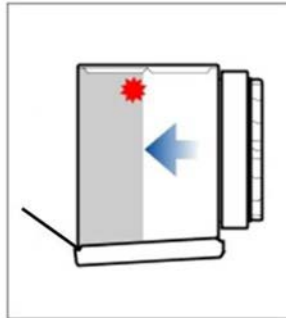

10.5.5 Further notes on defrosting

The drains of the drip trays must be heated (apart from plus-cold storage rooms), so that ice formation is prevented here.

11 Plans/diagrams

11.1 Electrics documentation

11.1.1 Fan motor connection diagram

See motor terminal box cover inside on the fan.