

Application guidelines

Inverter scroll compressors **VZH hybrid manifold VZH Gen3+DSH**

R410A



GENERAL INFORMATION	4
Scope	4
Benefits	4
PRODUCT INFORMATION	5
Oil management concept	5
System configuration	5
Dimensions	8
Tandem	8
Design pipe	9
General requirements	9
Suction separator	11
Oil equalization design	11
Design compressor mounting	12
General requirements	12
VZH178H Mounting feet	12
VZH208H Mounting feet	12
VZH257H / VZH278H Mounting feet	12
VZH301H Mounting feet	13
VZH410H / VZH465H Mounting feet	13
VZH354H Mounting kit	13
Design oil level sensor	14
General requirements	14
Manage operating envelope	15
Requirement	15
Manage speed limit	16
General requirements	16
Manage superheat	17
Requirement	17
System evaluation	17
Test, criteria and solutions	17
Manage off-cycle migration	19
Requirement	19
System evaluation	19
Refrigerant charge limit table	19
Manage oil in the circuit	20
Oil management system for hybrid manifolding	20
Oil management logic	20
Requirement	21
System evaluation	21
Test, criteria and solutions	21
Control logic	22
Safety control logic requirements	22
Short cycle protection	22
Defrost logic recommendations	23
Pump-down logic recommendations	23
Assembly line procedure	24
Handling	24
Ordering information	25
ORDERING INFORMATION	25
Compressor ordering codes	25
Accessory ordering codes	25
Accessories	26
Annex	28

General information

Scope

The application guideline describes the operating characteristics, design features and application requirements for hybrid manifolding of the Danfoss DSH fixed-speed compressor and the VZH inverter compressor in air-conditioning and heat pump applications.

- It is essential to respect all the instructions given in these guidelines; please refer to the instruction leaflet supplied with each compressor and the application guidelines for single compressors.

To ensure proper parallel installation and running conditions, the following recommendations must be followed:

- For additional system components related to specific application requirements, the supplier recommendations must always be respected.

Benefits

A parallel compressor installation refers to a system of interconnected compressors with a common suction line and a common discharge line. The technique of mounting compressors in parallel is also called manifolding. The hybrid manifolding in this application guideline refers to the manifolding of the Danfoss inverter compressor (VZH) and fixed speed compressor (DSH), which has several benefits.

The main reason is reduced operating cost through controlling capacity and power consumption to a greater extent. This is achieved by both staggering the compressor switch-on sequences and regulating the speed of the inverter compressor which allows the parallel system to continuously match its power with the capacity needed.

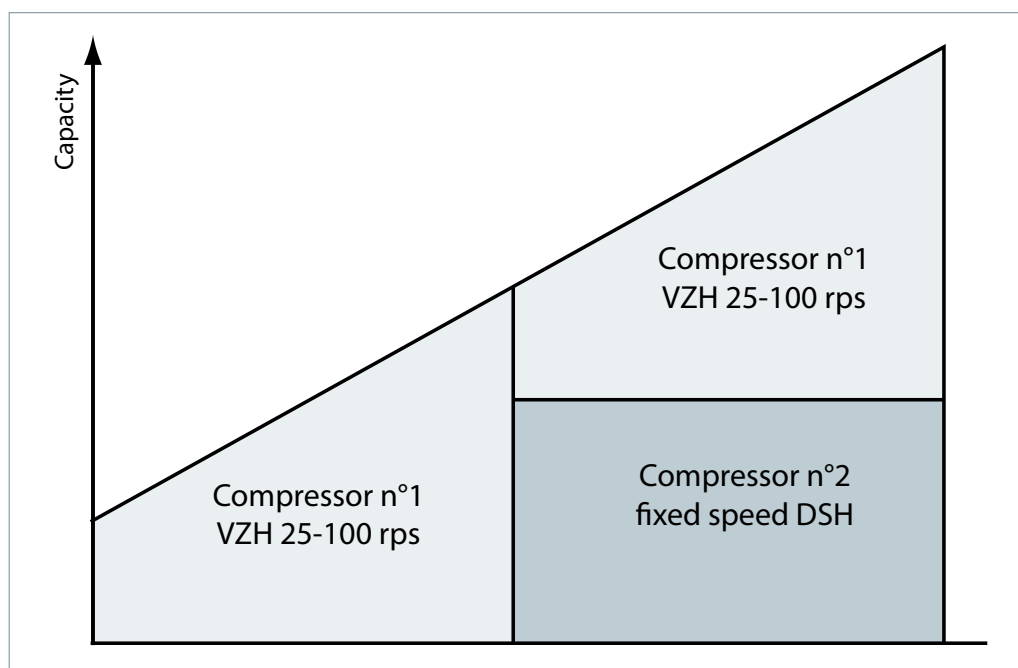

A second reason for manifolding the inverter compressor and the fixed speed compressor is improved part-load efficiency. In the variable speed+fixed speed parallel installation, the system can run either only the inverter compressor at lower load or both the inverter and fixed speed compressors at a higher load with the fixed speed compressor operating at 100% load.

Therefore, it will be possible to achieve a higher part-load efficiency.

Thirdly, the capacity of the hybrid manifolding system can be widely regulated, for example 10% to 100%. The continuous capacity regulation allows for accurate temperature control and a comfortable indoor environment.

Oil management concept

System configuration

Hybrid manifolding systems use the dynamic system for oil balance. The suction connections between the two individual compressors are interconnected by a special suction separator design that allows most of oil feed into variable speed compressors.

An optical-electrical oil level sensor fixed in a variable speed compressor monitors the compressor oil level.

If the oil level drops below the limit, the OEM main controller activates the oil management logic.

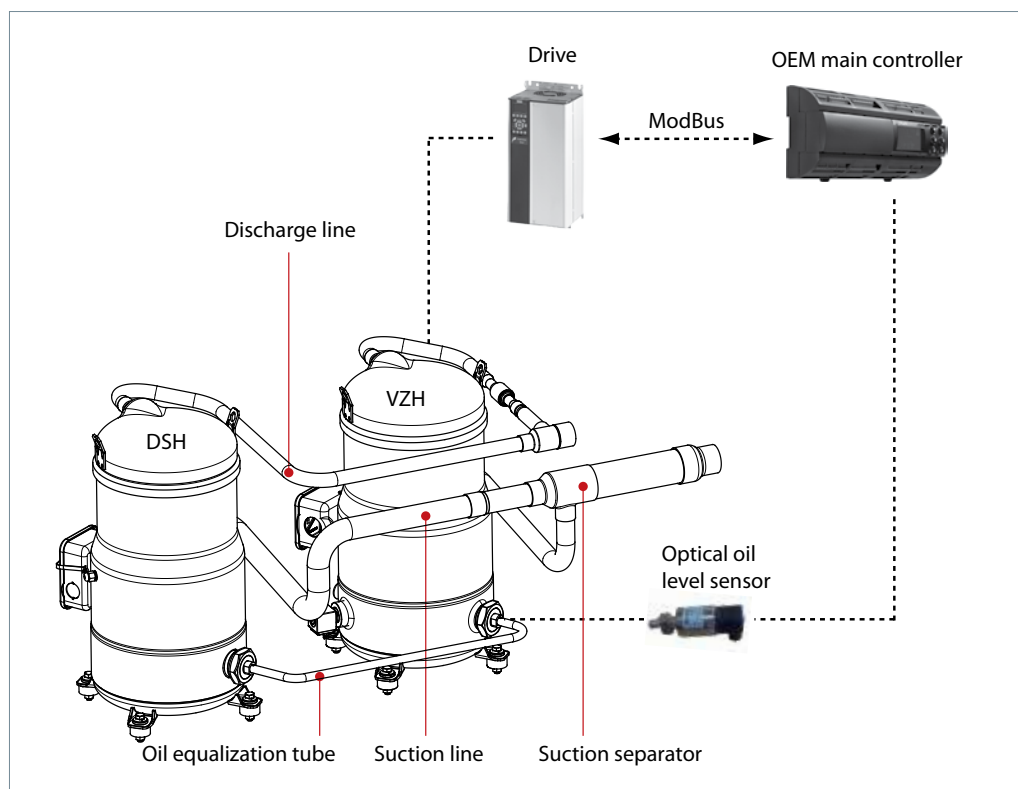

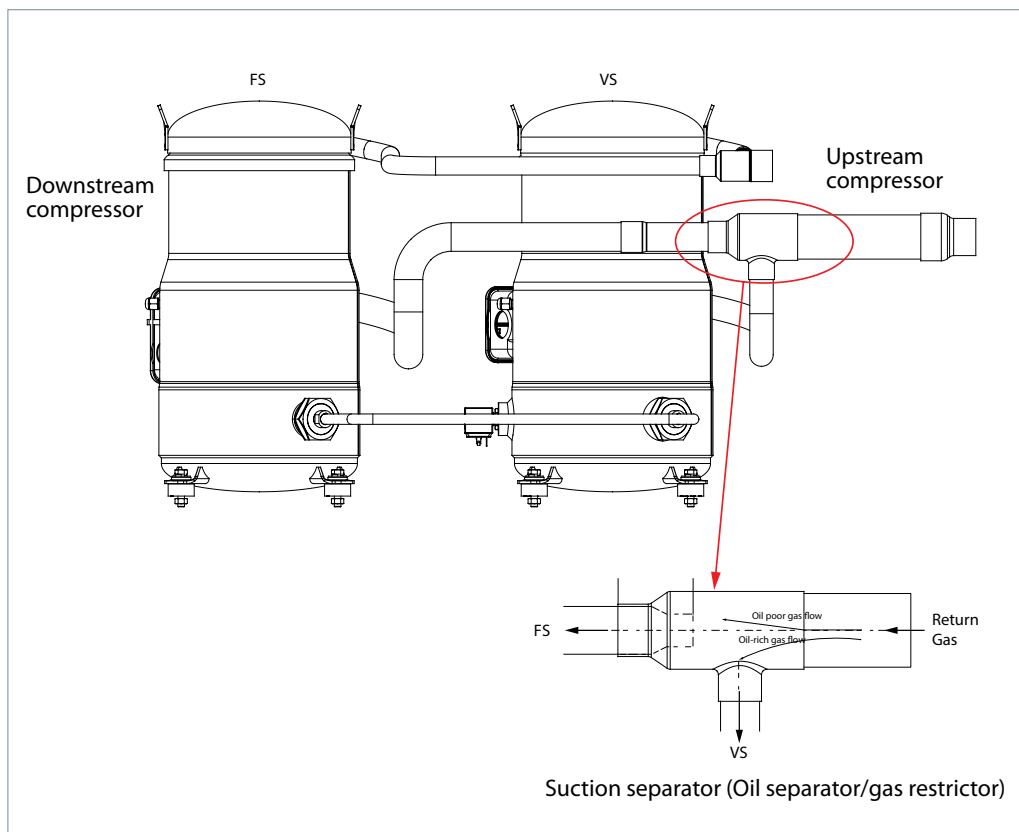

The hybrid manifold system uses the dynamic system for oil balance.

The suction connections of the two individual compressors are interconnected by a suction separator that integrates with the suction oil separator and the gas restrictor. The variable speed compressor (VS) is installed in the upstream position which appears first on suction line and fixed speed compressor (FS) is installed on downstream position.

The oil which clings back along the main suction line is separated by the suction separator which

returns most of the oil in the suction gas to the upstream compressor. The suction separator creates a slight pressure drop to ensure lower sump pressure between two compressors is well balance when fixed speed compressor is ON and the inverter compressor is running at maximum speed. When the variable speed compressor runs at any frequency below maximum speed, the sump pressure in the fixed speed compressor is lower than the variable speed compressor, and driven by the sump pressure difference, the excess oil from the variable speed compressor runs into the fixed speed compressor sump.

Approved hybrid tandem configurations and capacity range

Different configurations of hybrid tandems are possible. All VZH models (high/low pressure ratio/ different voltage) could be manifolded with fixed speed compressors.

Danfoss VSD : VZH compressor Drive™ 380-480 Volt

Model	Description	FS: 50Hz, VS:100Hz		FS: 60Hz, VS: 100Hz	
		kW	TR	kW	TR
VZH178H	VZH088+DSH90	68.9	19.6	73.9	21.0
VZH208H	VZH088+DSH120	77.7	22.1	83.7	23.8
VZH257H	VZH117+DSH140	97.8	27.8	105.2	29.9
VZH278H	VZH117+DSH161	101.6	28.9	110.1	31.3
VZH301H	VZH117+DSH184	106.2	30.2	115.7	32.9
VZH354H	VZH170+DSH184	137	39.1	146	41.9
VZH410H	VZH170+DSH240	151.9	43.2	164.9	46.9
VZH465H	VZH170+DSH295	164.6	46.8	179.3	51

TR: Ton of Refrigeration

Refrigerant: R410A

Standard rating conditions: ARI standard

Evaporating temperature: 7.2°C

Superheat: 11.1k

Condensing temperature: 54.4°C

Subcooling: 8.3k

Subject to modification without prior notification

Data given for motor code G compressor – for full data details and capacity tables, please refer to Coolselector2

www.coolselector.danfoss.com

Dimensions

Tandem

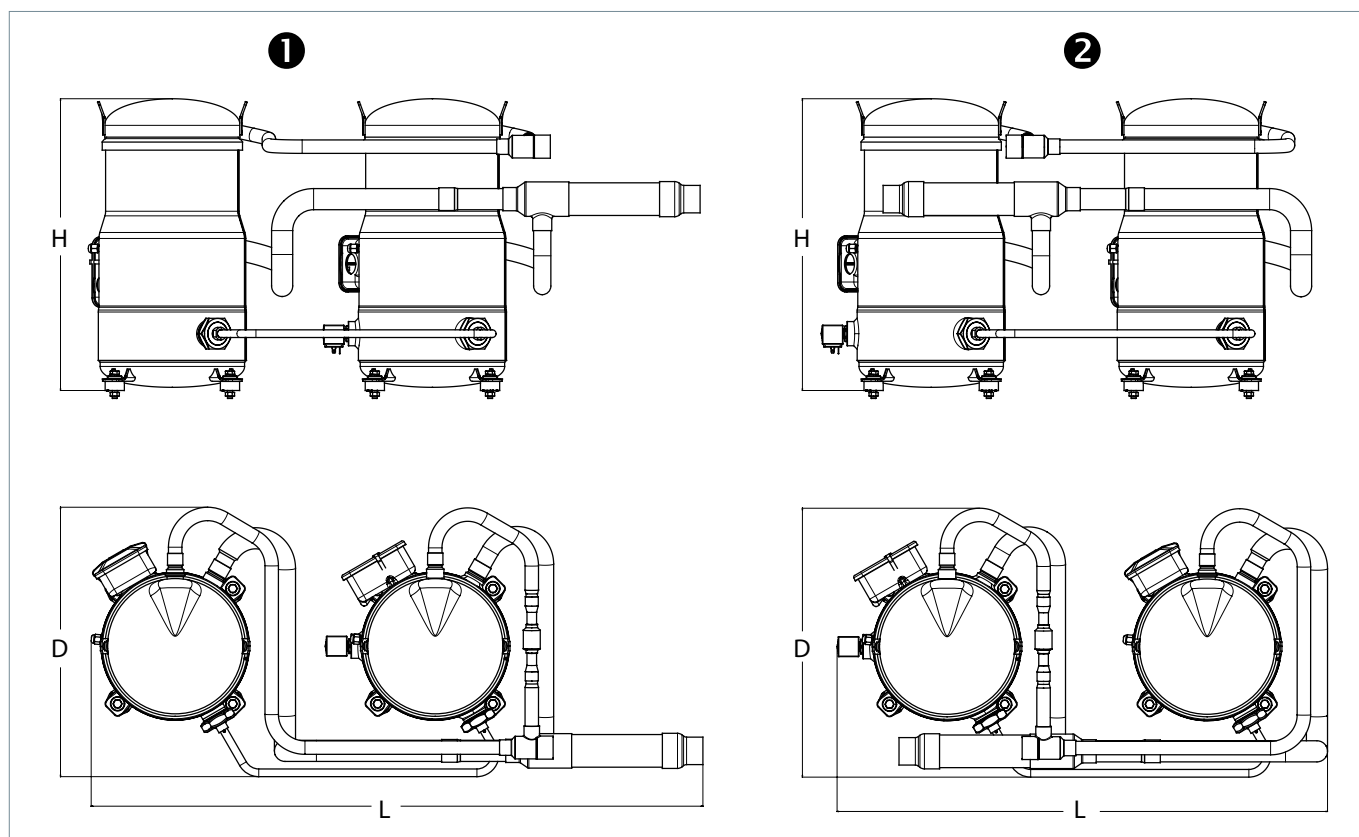

Tandem model	Composition	Outline drawing number	Suction	Discharge	L (mm)	D (mm)	H (mm)
VZH178H	VZH088+DSH090	① 8560156	1" 5/8	1" 3/8	1011	445	482
		② 8560155	1" 5/8	1" 3/8	811	445	482
VZH208H	VZH088+DSH120	① 8560154	1" 5/8	1" 3/8	1011	445	540
		② 8560153	1" 5/8	1" 3/8	811	445	540
VZH257H	VZH117+DSH140	① 8560152	1" 5/8	1" 3/8	1024	445	540
		② 8560151	1" 5/8	1" 3/8	811	445	540
VZH278H	VZH117+DSH161	① 8560152	1" 5/8	1" 3/8	1024	445	540
		② 8560151	1" 5/8	1" 3/8	811	445	540
VZH301H	VZH117+DSH184	① 8560150	1" 5/8	1" 3/8	1116	445	555
		② 8560149	1" 5/8	1" 3/8	811	445	555
VZH354H	VZH170+DSH184	① 8560148	2" 1/8	1" 5/8	1241	583	682
		② 8560147	2" 1/8	1" 5/8	890	583	682
VZH410H	VZH170+DSH240	① 8556271	2" 1/8	1" 5/8	1245	583	682
		② 8556270	2" 1/8	1" 5/8	953	583	682
VZH465H	VZH170+DSH295	① 8556271	2" 1/8	1" 5/8	1245	583	682
		② 8556270	2" 1/8	1" 5/8	953	583	682

Tandem configurations are achieved by assembling individual compressors

Design pipe

General requirements

Proper piping practices should be employed to:

1. Ensure adequate oil return, even under minimum load conditions (fixed speed compressor off, variable speed compressor at minimum speed, minimum evaporating conditions). If minimum refrigerant velocity cannot be reached, it is strongly recommended that an oil separator is used. For a validation test, the see section "Manage oil in the circuit".

2. Prevent condensed liquid refrigerant from draining back into the compressor when stopped (discharge piping upper loop). For validation tests, see the section "Manage off-cycle migration".

General recommendations are described in the figures below:

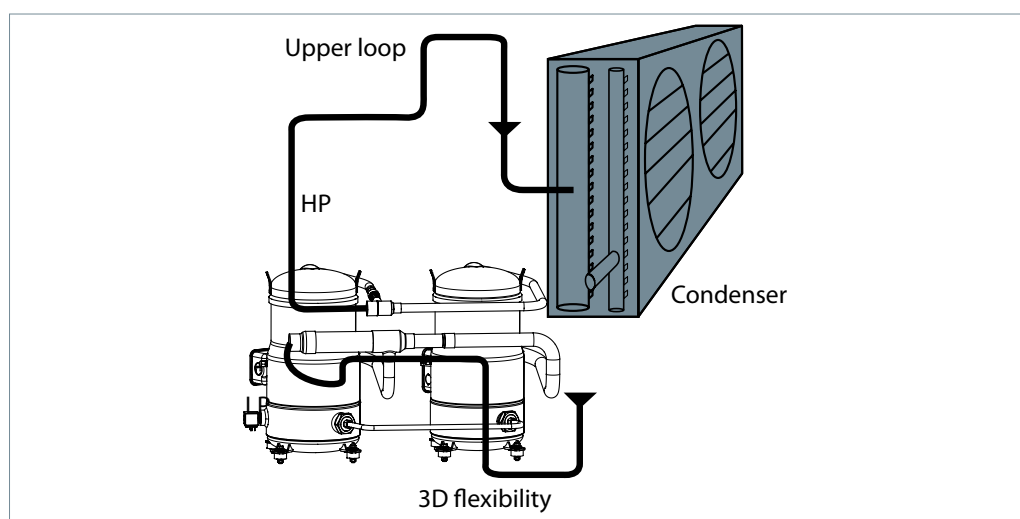
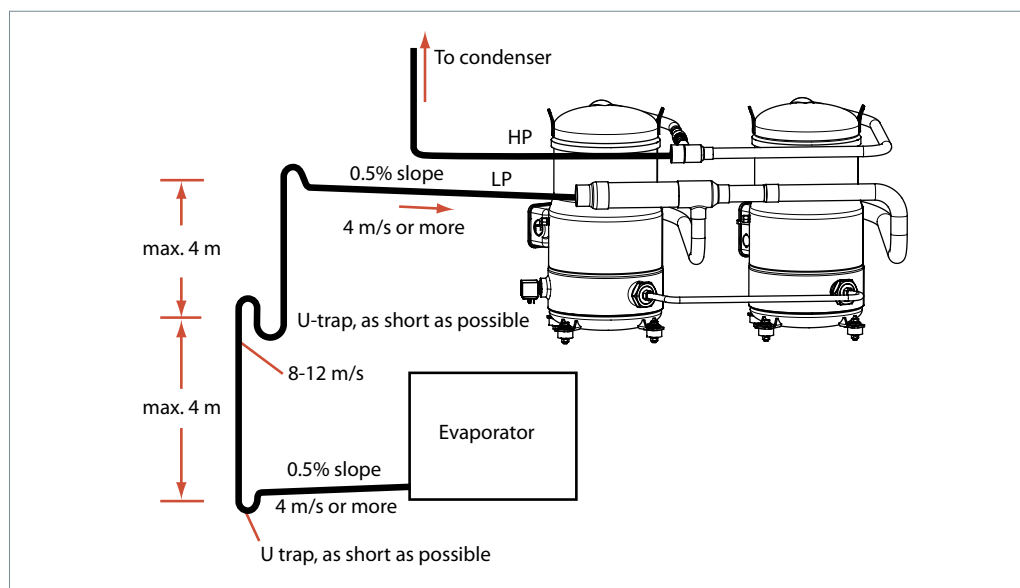

3. Piping should be designed with adequate three-dimensional flexibility to avoid excess vibration. It should not be in contact with the surrounding structure, unless a proper tubing mount has been installed. For more information

on noise and vibration, see the section "Sound and vibration management" in the application guideline for Danfoss VZH Gen3 scroll compressors (AB300034185311en).

Design pipe

Suction on left

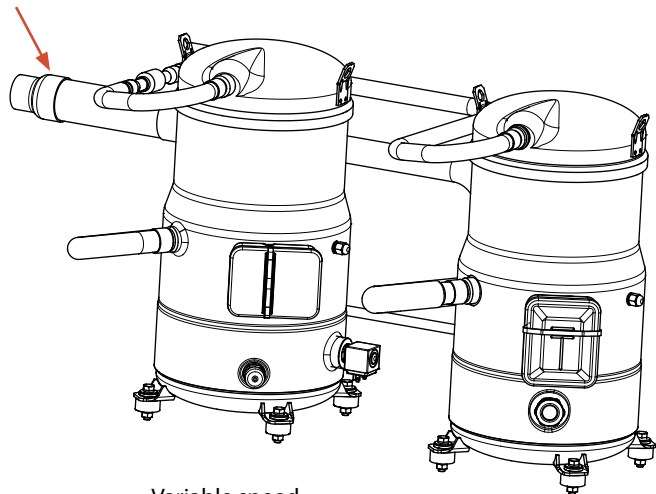

Variable speed

Fixed speed

Suction on right

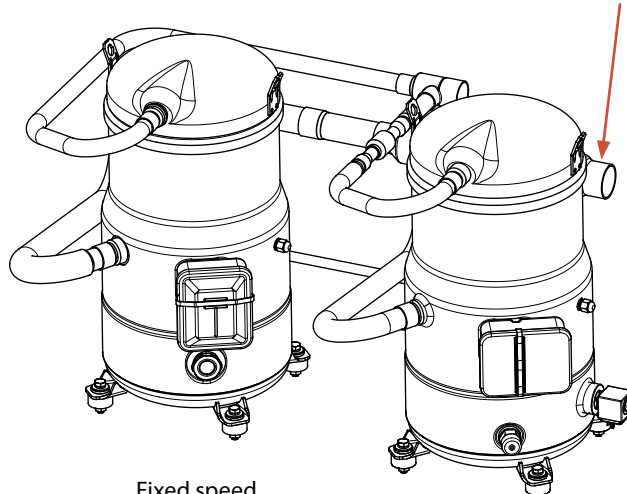

Fixed speed

Variable speed

Fixed speed	Variable speed	Tandem model	Suction direction	Hz of FS compressor	Suction separator code	Tandem accessory kit code
DSH090	+	VZH088	VZH178H	Left/Right	50	120Z0676 120Z0653 (with 24V oil level sensor) 120Z0654 (with 230V oil level sensor)
					60	120Z0675 120Z0653 (with 24V oil level sensor) 120Z0654 (with 230V oil level sensor)
DSH120	+	VZH088	VZH208H	Left/Right	50	120Z0664 120Z0651 (with 24V oil level sensor) 120Z0652 (with 230V oil level sensor)
					60	120Z0658 120Z0651 (with 24V oil level sensor) 120Z0652 (with 230V oil level sensor)
DSH140	+	VZH117	VZH257H	Left/Right	50	120Z0666 120Z0653 (with 24V oil level sensor) 120Z0654 (with 230V oil level sensor)
					60	120Z0665 120Z0653 (with 24V oil level sensor) 120Z0654 (with 230V oil level sensor)
DSH161	+	VZH117	VZH278H	Left/Right	50	120Z0665 120Z0653 (with 24V oil level sensor) 120Z0654 (with 230V oil level sensor)
					60	120Z0674 120Z0653 (with 24V oil level sensor) 120Z0654 (with 230V oil level sensor)
DSH184	+	VZH117	VZH301H	Left/Right	50 & 60	120Z0656 120Z0651 (with 24V oil level sensor) 120Z0652 (with 230V oil level sensor) 120Z0682 (with 24V oil level sensor)
						Left
60	120Z0655 120Z0655 120Z0681 (with 230V oil level sensor)					
	Right	50	120Z0687 120Z0687 120Z0682 (with 24V oil level sensor) 120Z0681 (with 230V oil level sensor)			
60		120Z0687 120Z0687 120Z0682 (with 24V oil level sensor) 120Z0681 (with 230V oil level sensor)				
DSH240	+	VZH170	VZH410H	Left/Right	50 & 60	120Z0657 120Z0649 (with 24V oil level sensor) 120Z0650 (with 230V oil level sensor)
DSH295	+	VZH170	VZH465H	Left/Right	50 & 60	120Z0655 120Z0649 (with 24V oil level sensor) 120Z0650 (with 230V oil level sensor)

Note:

The tandem accessory includes oil equalization kits and oil level sensor. For compressors that need a UL certificate, please order the accessory kit with the 24V oil level sensor.

+

Design pipe

Suction separator

The suction connections of the two individual compressors are interconnected by a suction separator, which is supplied as an accessory.

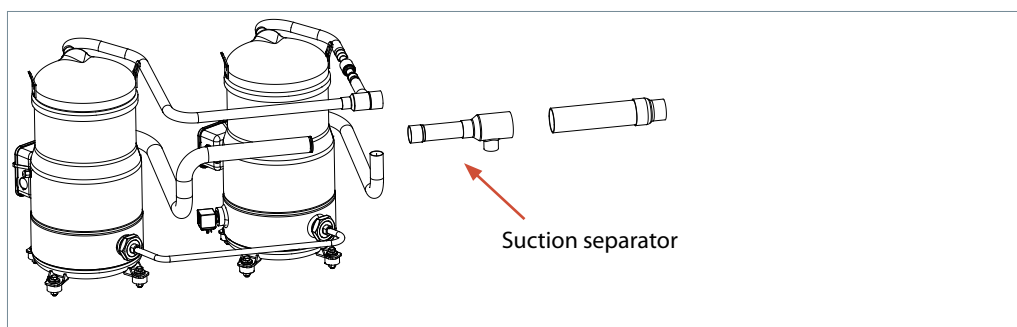

Oil equalization design

The two compressors are connected by a 1/2" or 3/4" oil equalization pipe. To fix the oil equalization connection rotolock, use the adaptor sleeves

and the seal gasket which were included in the tandem accessory kit.

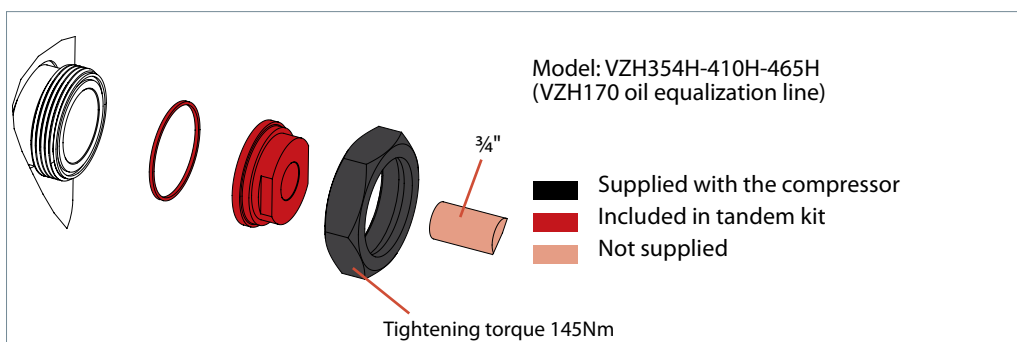
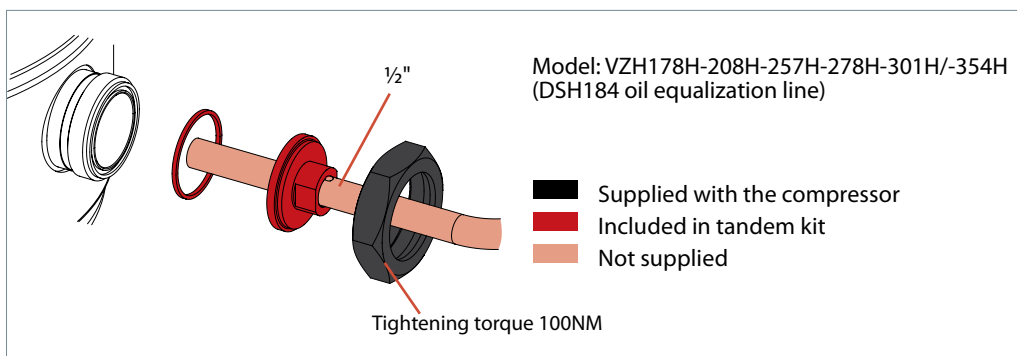

Design compressor mounting

General requirements

The tandem is fixed to the frame using the flexible grommets that are supplied with

the compressor or which are included in the accessory kit.

VZH178H Mounting feet

The compressors are fixed to the frame using rubber grommets, mounting sleeves, and washers (supplied with the compressors).

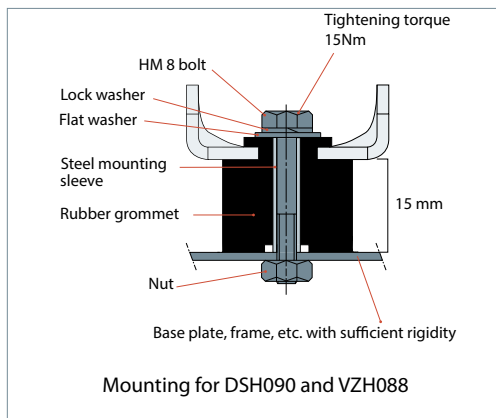

VZH208H Mounting feet

The compressors are fixed to the frame using rubber grommets, mounting sleeves, and washers (supplied with the compressors).

connection is at the same level for both compressors, an additional 7mm rigid spacer must be added under VZH088 (see drawing. The 7 mm rigid spacer is supplied with the tandem accessory kit).

Because VZH088 is 7 mm smaller than DSH120, in order to ensure that the oil equalization

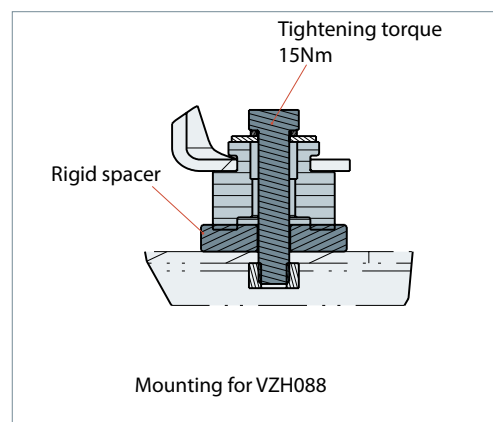
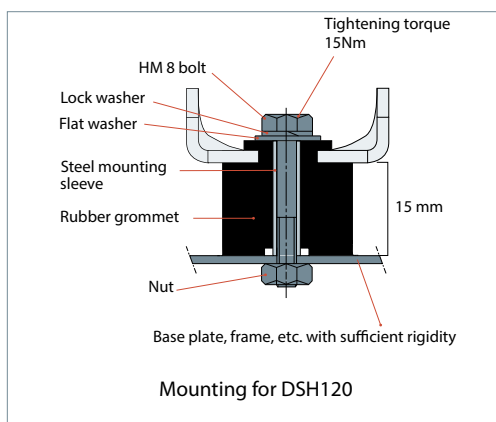

VZH257H / VZH278H Mounting feet

The compressors are fixed to the frame using rubber grommets, mounting sleeves, and washers (supplied with the compressors).

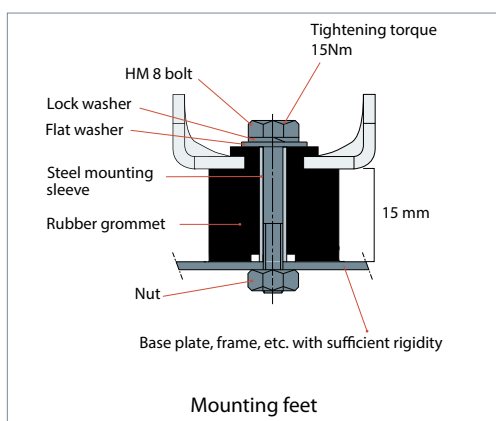

Design compressor mounting

VZH301H Mounting feet

The compressors are fixed to the frame using rubber grommets, mounting sleeves, and washers (supplied with the compressors).

Because VZH117 is 7 mm smaller than DSH184, in order to ensure that the oil equalization

connection is at the same level for both compressors, an additional 7mm rigid spacer must be added under VZH117 (see drawing. The 7 mm rigid spacer is supplied with the tandem accessory kit).

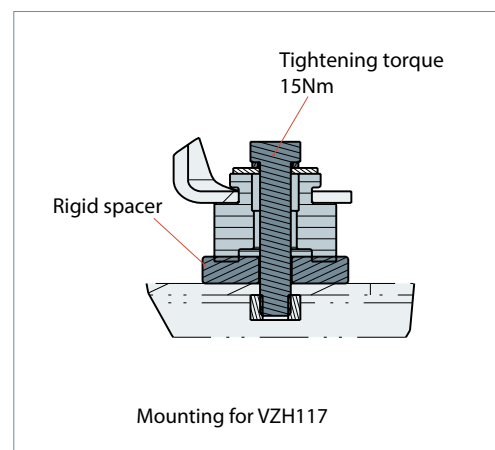
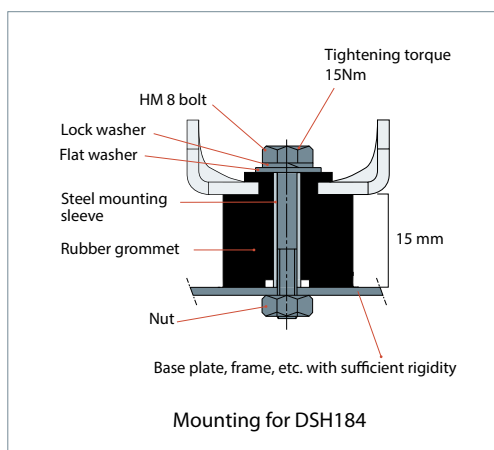

VZH410H / VZH465H Mounting feet

The compressors are fixed to the frame using rubber grommets, mounting sleeves, and washers. The VZH mounting kits are supplied

with the VZH compressor, and DSH mounting kits are included in the tandem accessory kit.

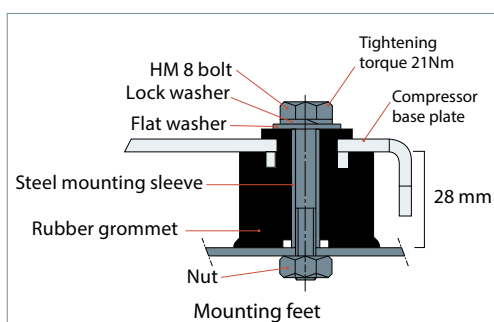

VZH354H Mounting kit

The compressors are fixed on the frame using rubber grommets, mounting sleeves, washers (delivered with the compressors).

Because DSH184 is 14mm smaller than VZH170, in order to have oil equalization connection at the same level for both compressors, two additional 7mm rigid spacers must be added under DSH184 (See below drawing, two 7mm rigid spacers are provided in Tandem accessory kit).

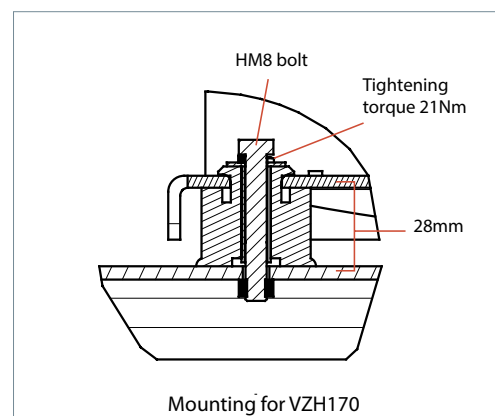
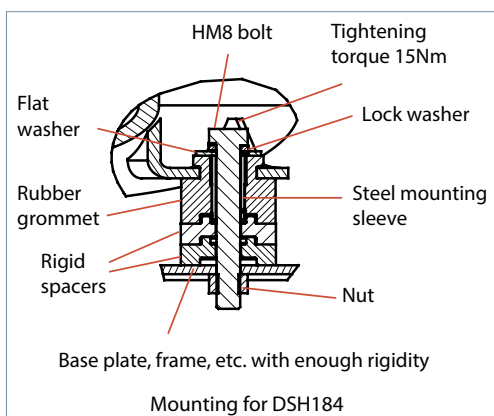

Design oil level sensor

General requirements

Oil level sensor is a special component which assembles on variable speed compressor. It is

provided in oil level sensor accessory kit.

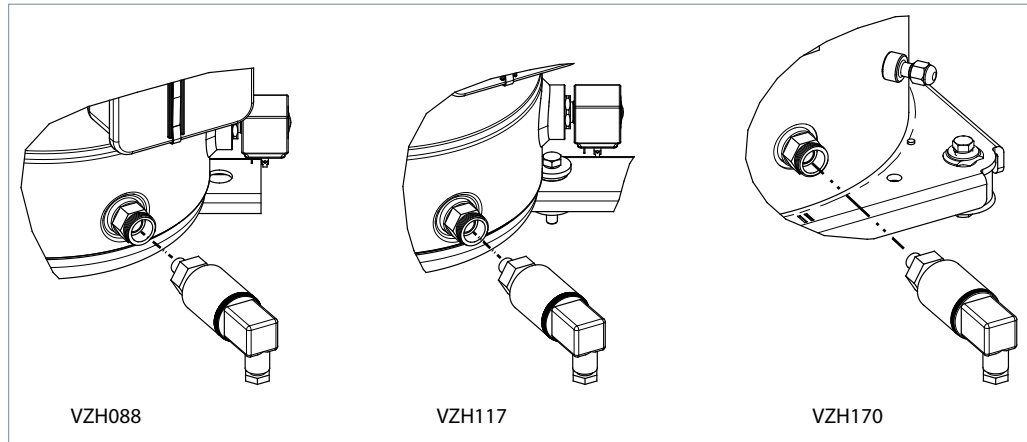

GENERAL INFORMATION

PRODUCT INFORMATION

SYSTEM DESIGN

ORDERING INFORMATION

Manage operating envelope

Requirement

The operating envelope for hybrid manifolding is shown below, and guarantees reliable operation of the compressor for steady-state operation. The steady-state operation envelope is valid for a suction superheat of between 5K and 30K.

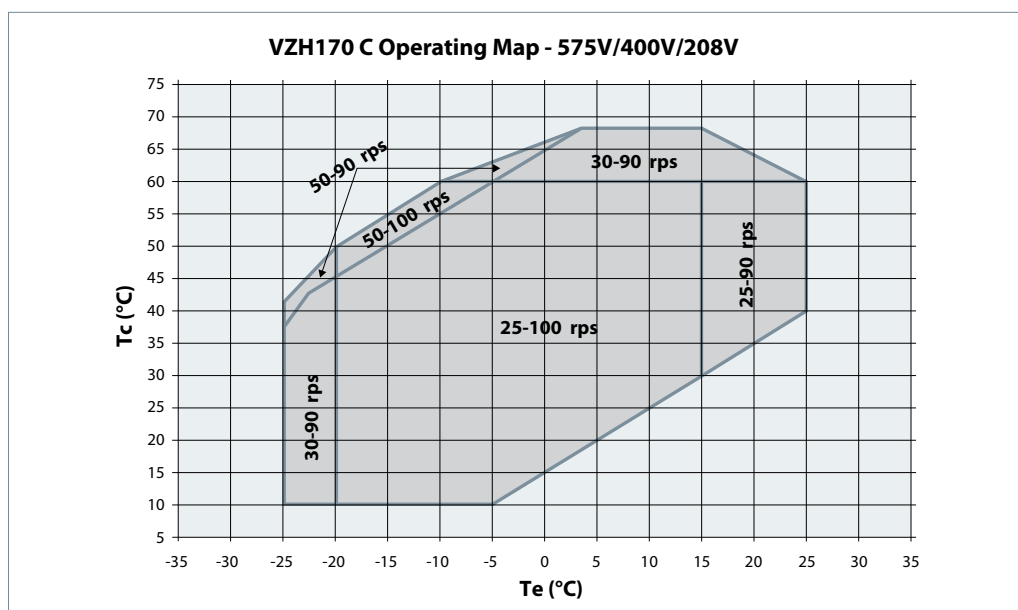
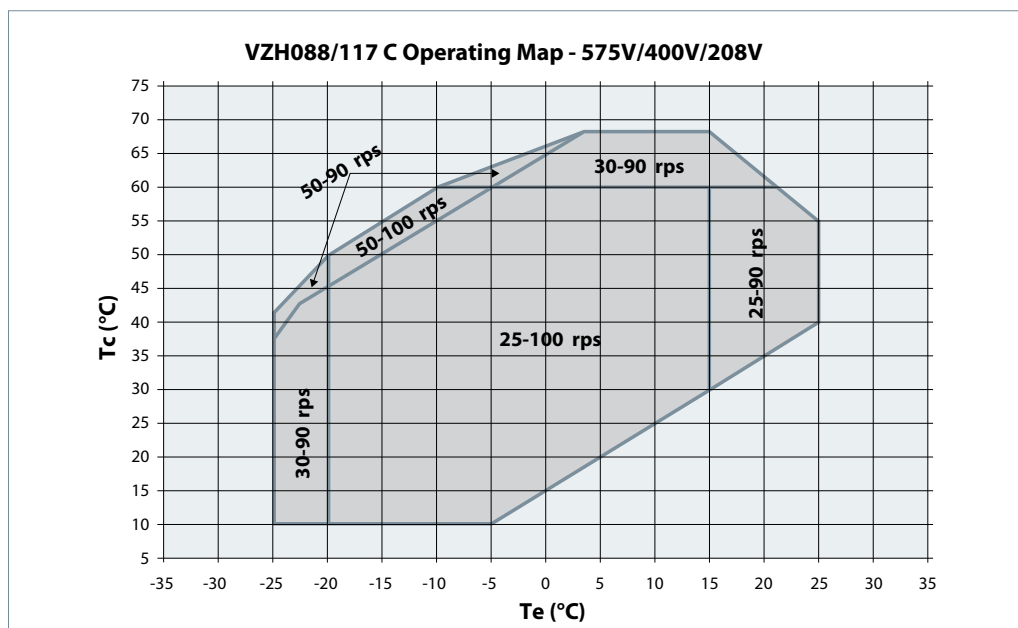

Note:

- The solid line envelope is valid for a suction superheat within 5K (9°F) at nominal voltage. Higher suction superheat may lead to discharge temperatures above 135°C (275°F). For superheat between 5K and 11K, this top left envelope might be reduced by condensing temperature of 1°C or 2°C (1.6°F to 3.2°F) in order to keep discharge T° below 135°C (275°F). For superheat above 11K (20°F), the envelop will further be reduced based on 135°C (275°F) discharge temperature restriction.
- For 380V power input, permitted highest condensing temperature will decrease accordingly: 25-100rps, condensing temperature from 60°C to 56°C(140°F to 133°F); 30-90rps, condensing temperature from 68°C to 65°C(154°F to 149°F).

Pressure settings	R410A	
	bar (g)	psi (g)
Working pressure range low side	2.3~15.7	33.36~227.7
Maximum high pressure safety switch setting	48.7	706.33
Minimum low pressure safety switch setting	1.5	21.75
Recommended pump-down switch settings	1.5 bar below nominal evaporating pressure	21 psi below nominal evaporating pressure with minimum of
Minimum low pressure pump-down switch setting	2.3bar(g)	33 psig

Manage speed limit

General requirements

Speed limit guarantees compressor reliability and must be respect. Details refer to

single VZH M/L GEN3 guideline "Manage speed limit"

GENERAL INFORMATION

PRODUCT INFORMATION

SYSTEM DESIGN

ORDERING INFORMATION

Manage superheat

During normal operation, refrigerant enters the compressor as a superheated vapour. Liquid flood back occurs when some of the refrigerant entering the compressor is still in a liquid state.

Liquid flood back can cause oil dilution and, in extreme situations, lead to liquid slugging that can damage compression parts.

Requirement

In the steady-state condition, the expansion device must ensure a suction superheat of between 5k and 30k.

System evaluation

Basic unit single exchanger as evaporator and condenser	Advance unit Multiple exchangers as evaporator or condenser (heat-recovery, exchanger, four-pipe chiller...)	Non-reversible	Reversible	Suction accumulator	Test
X		X		Optional	Pass liquid flood back test
X		-	X	Recommended	Pass liquid flood back test Pass defrost test
	X	X		Mandatory	Pass liquid flood back test
	X		X	Mandatory	Pass liquid flood back test Pass defrost test

Test, criteria and solutions

Test No	Purpose	Test condition	Pass criteria	Solutions
Liquid flood back test	Steady-state	<p>Liquid flood back testing must be carried out under expansion valve threshold operating conditions:</p> <p>Variable speed On at min.speed / fixed speed Off</p> <p>Running conditions corresponding to the lowest foreseeable evaporation, and highest foreseeable condensation</p> <p>In case of reversible system, the test must be done in both cooling and heating mode If advanced unit, test in all possible configurations</p>	Suction superheat >5k	<ol style="list-style-type: none"> 1. Check expansion valve selection and setting (EXV) check measurement chain and PID. 2. Add a suction accumulator*
	Transient	<p>Tests must be carried out in the most unfavourable conditions:</p> <ul style="list-style-type: none"> • fan staging • compressor ramping up and down 	The oil superheat must not be more than 30 sec below the safe limit defined in the dilution chart (see graph below)	
Defrost test	Check liquid flood back during defrost cycle	The defrost test must be carried out in the most unfavourable conditions (at 0°C evaporating temperature)	The oil superheat must not be more than 30 sec below the safe limit defined in the dilution chart (see graph below)	<ol style="list-style-type: none"> 1. In reversible systems, the defrost logic can be worked out to limit the liquid flood back effect. (For more details see "Control logic") 2. Add a suction accumulator*

* A suction accumulator offers protection by trapping the liquid refrigerant upstream from the compressor. The accumulator should be sized at least 50% of the total system charge. The suction accumulator dimensions can impact oil return (gas velocity, oil return, hole size etc.), and therefore the oil return has to be checked according to the "Manage oil in the circuit" section.

Manage superheat

GENERAL INFORMATION
PRODUCT INFORMATION
SYSTEM DESIGN
ORDERING INFORMATION

The oil temperature sensor must be placed between the oil sight glass and the compressor baseplate for fixed speed compressor, and beside the oil level sensor for the variable speed compressor. Use a little thermal paste to improve conductivity. The sensor must also be thermally insulated correctly from the ambience.

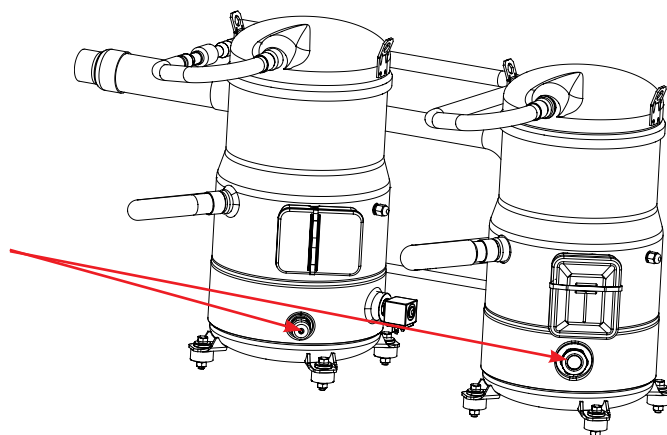

Oil superheat is defined as:
(Oil temperature - Evaporating temperature)

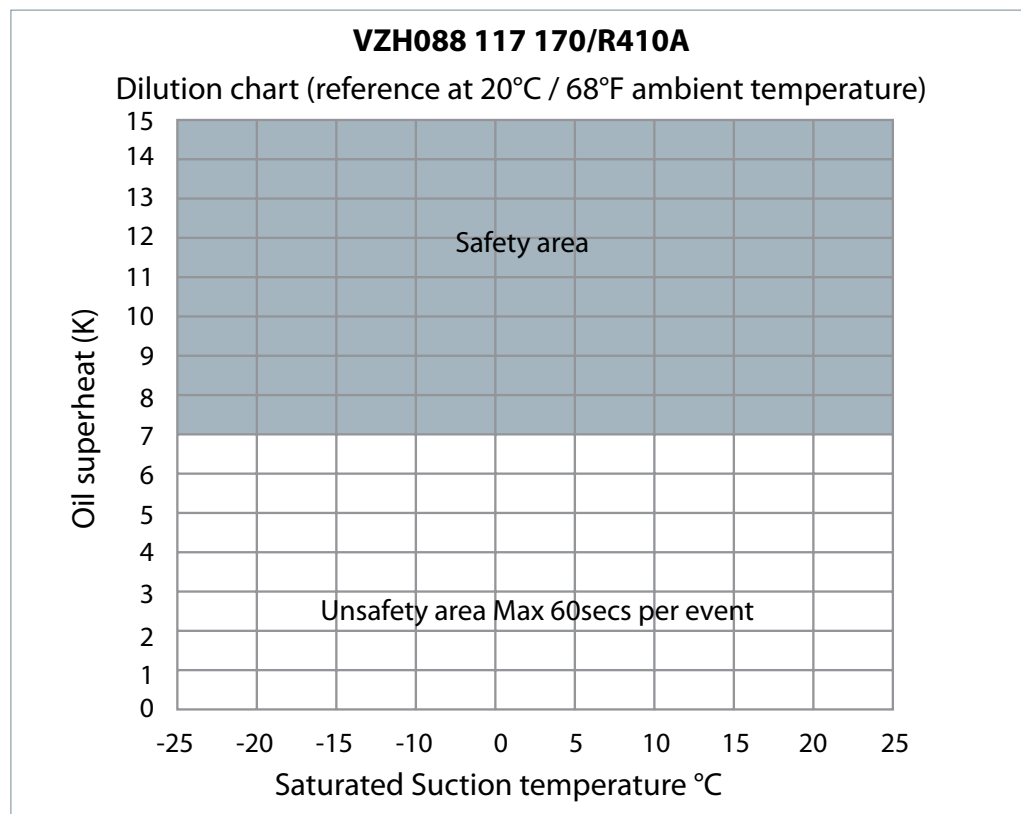

Manage off-cycle migration

Off-cycle refrigerant migration happens:

- when the compressor is located at the coldest part of the installation, and refrigerant vapour then condenses in the compressor, or

- directly in the liquid phase as the result of gravity. When the compressor starts running again, the refrigerant diluted in the oil generates poor lubrication conditions. In extreme situations, this leads to liquid slugging that can damage compressor parts.

Requirement

The amount of liquid refrigerant in the compressors must not exceed the charge limit.

System evaluation

Non split	Split	Below charge limit	Above charge limit	Surface sump heater*	Non-return valve	Liquid line solenoid valve**	Pump-down cycle***
X		X		Optional	Mandatory	Mandatory	Optional
X			X	Mandatory	Mandatory	Mandatory	Recommended
	X	-	-	Mandatory	Mandatory	Mandatory	Recommended

*Surface sump heater

The surface sump heaters are designed to protect the compressor against off-cycle refrigerant migration. Additional heater power or thermal insulation is needed in case the ambient temperature falls below -5°C and the wind speed is above 5 m/sec. The heater must be turned on whenever all the compressors are off. Surface sump heater accessories are available from Danfoss (see the "Accessories" section).



**Liquid line solenoid valve (LLSV)

An LLSV is used to isolate the liquid charge on the condenser side, thereby preventing refrigerant being transferred to the compressor during off-cycles. The electronic expansion valve that closes automatically including in power shut down situation can replace the LLSV. The quantity of refrigerant on the low-pressure side of the system can be further reduced by using a pump-down cycle in association with the LLSV.

***Pump-down cycle

By decreasing pressure in the sump, pump down:

- evacuates refrigerant from the oil
- sets the sump saturating pressure much lower than the ambient temperature, and as a result, refrigerant condensation is avoided in the compressor.

Pump-down switch setting must be set higher than 2.3 bar(g).

For more details on pump-down cycle see the section "Control logic".

Refrigerant charge limit table

Tandem models	Refrigerant charge limit(kg)
VZH178H/VZH208H	8.0
VZH257H/VZH278H/VZH301H	10.0
VZH354H/VZH410H/VZH465H	15.0

Manage oil in the circuit

Non return valve

⚠ Non-return valve at discharge prevents from liquid or gas migration. Selection of non-return valve is a trade-off between pressure dropping at high speed, and the state of the valve stability while at low speed. See Section Prevent off cycle migration §Test and components required per application to know when to use non return valve

The following table displays present Danfoss non-return valve selection per each specific compressor. DSH are with internal NRV, no need external NRV.

Compressor model	NRV model
VZH088	NRV 16
VZH117	NRV 19
VZH170	NRV 22

Oil management system for hybrid manifolding

The oil management system architecture for hybrid manifolding is described below.

An oil equalization tube between the variable speed compressor and the fixed speed compressor is used to maintain the oil balance.

An oil level sensor need to be installed on the variable speed compressor. The oil level sensor monitors the compressor oil level and send oil level signal to OEM main controller. When oil level is below the minimal, OEM controller enter in oil management mode to recover a proper oil level in compressor. If oil level cannot be recovered, controller stop the system.

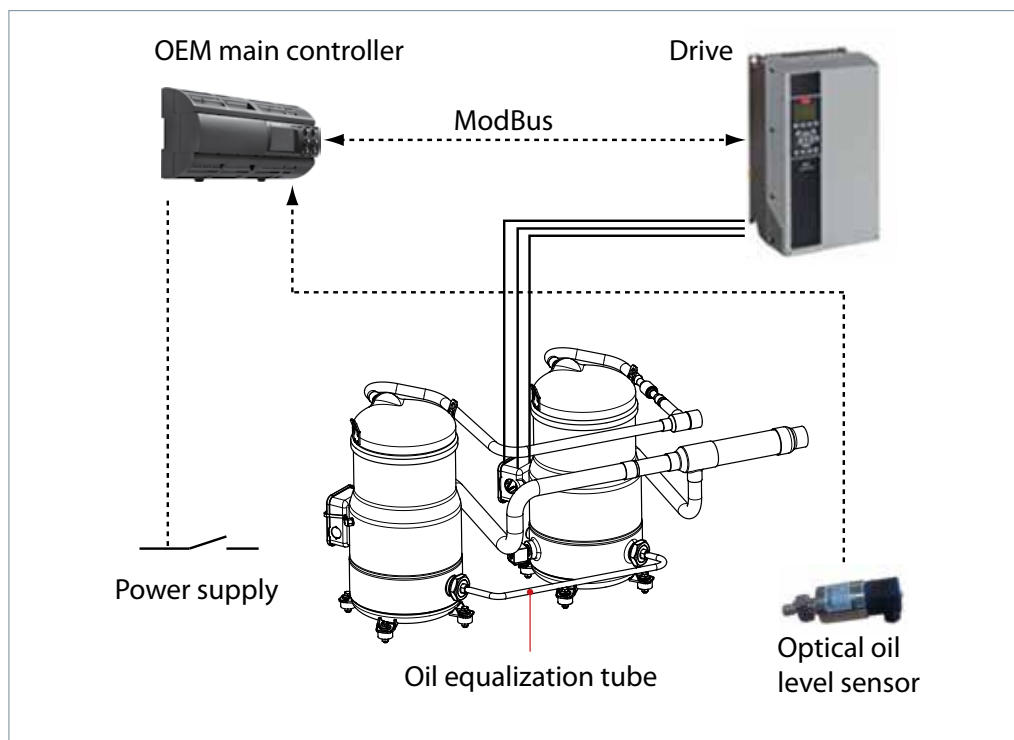

Oil management logic

In order to maintain the proper oil level in the compressors, an oil management control logic needs be implemented in the OEM controller.

The oil management control logic must include three steps.

1. In the case of low oil level detection, an oil balance mode (Variable speed on, Fixed speed off) is activated to recover oil from fixed speed to variable speed.

2. If oil level cannot be recovered in VS compressor, controller go to Oil boost Mode (Variable speed on, Fix Speed on) in order to recover oil trapped in system.

3. If the oil level is still below the limit after a full oil balance action and oil boost action have been completed, the controller must enter in protection mode, and stop the system in alarm.

For more detailed oil management logic, please refer to "Oil management logic" in the annex.

Manage oil in the circuit

Requirement

Fixed speed compressor: The oil level must be visible or full in the sight glass when the compressor is running and when all the compressors in the circuit are stopped.

Variable speed compressor: This compressor is equipped with an oil level switch located at the minimum acceptable level. If the oil level drops below this limit, the controller must follow the oil logic (See "Oil management logic" in the annex).

R Fixed speed compressor oil returned status need be monitored in qualification test by normal OSG on FS compressor or additional oil level switch placed on FS OSG, the OEM should make sure enough oil in FS compressor by test on their own unit.

System evaluation

Basic unit Single exchanger as evaporator and condenser	Advance unit Multiple exchangers as evaporator or condenser (heat-recovery, exchanger, four-pipe chiller...)	Non-reversible	Reversible	Non-split	Split	Oil separator	Test
X		-	-	X		Optional	Pass tests 1 & 2
	X	-	-	X		Recommended	Pass tests 1 & 2
-	-	-	-	-	X	Mandatory	Pass tests 1, 2 & 3

Test, criteria and solutions

Test no.	Purpose	Test condition	Pass criteria	Solutions
1	Oil return test under minimum mass flow	Variable speed On at minimum speed / Fixed speed Off Running condition corresponds to lowest foreseeable evaporation, and highest foreseeable condensation on the system Running for 6 hours	Variable speed: No lack of oil alarm No more than two oil boost cycles per hour	
		For a reversible system, perform the test in both heating and cooling modes. If it is an advanced unit, test in all possible configurations Variable speed On at minimum speed / Fixed speed On Running condition corresponding to lowest foreseeable evaporation, and highest foreseeable condensation on the system Running for 6 hours	Variable speed: No lack of oil alarm Fixed speed: Oil visible in sight glass	Look for potential oil trap Increase oil boost duration Top up with oil, generally 4% of the total system refrigerant charge (in weight) Oil separator can be added
2	Check oil management control logic is working	Variable speed On at 50 rps for VZH088-117 or 40 rps for VZH170 / Fixed speed On Running conditions corresponding to the lowest foreseeable evaporation, and the highest foreseeable condensation on the system. Running for 6 hours For a reversible system, perform the test in both heating and cooling modes. If it is an advanced unit, test in all possible configurations	No more than two oil balance cycles per hour Fixed speed: Oil visible in sight glass	Look for potential oil trap Increase oil boost duration Top up with oil, generally 4% of the total system refrigerant charge (in weight). If more than 4% is used, look for a potential oil trap in the system Oil separator can be added
3	Oil return in split system	Since each installation is unique, tests 1 and 2 cannot fully validate the oil return The oil level must be checked and adjusted at commissioning	Fix speed: Oil visible in sight glass No more than two oil balance cycles per hour	The oil separator is mandatory Pay special attention to "Piping design" Top-up with oil, generally 4% of the total system refrigerant charge (in weight). If more than 4% is used, look for a potential oil trap in the system

Safety control logic requirements

Safeties	Tripping conditions		Re-start conditions	
	Value	Time	Value	Time
HP switch	See the pressure settings table in the "Manage operating envelope section"	Immediate, no delay No by-pass	Conditions back to normal Switch closed again	Manual reset
LP safety switch				Max. 5 auto resets during a 12-hour period, then manual reset
Electronic module (only for SH180-240-295)	Contact M1-M2 opened			Max. 5 auto resets during a 12-hour period, then manual reset

Short cycle protection

Minimum run time is necessary to ensure proper oil return to the compressor. A 3 minutes minimum run time is usually recommended but some systems may require more time to establish a proper superheat and a stable oil return. Additionally, compressor must not exceed a maximum of 12 starts per hour. 12 starts per hour must not be considered as an average, this

is the maximum number of starts acceptable for a limited period to ensure enough time for oil return after start-up. Short cycle protection can be done either by the drive or the unit controller. The following table describes the parameters to adjust depending on short cycle protection selected

Drive parameters	Description	Value	Default	
Short cycle protection is done by unit controller				
28.00	Short cycle protection	Short cycle protection done in unit controller: (preferred option)	Disable	Enable
Short cycle protection is done in drive; LP (low pressure) protection must be connected to T27 to keep LP protection during minimum running time. Terminal 27 (Par 5.12) must be set to "Coast inverse" If Modbus is used it is not necessary to connect terminal 27, but a "Coasting" command must be sent to be able to stop compressor in case of an alarm during minimum run time				
28.00	Short cycle protection	Short cycle protection done by the drive.	Enable	Enable
28.01	Interval between starts	Start command is ignored until the timer (300s) has elapsed. Only then, can the compressor start.	300 sec	300sec
28.02	Minimum Run time	The compressor cannot stop until the set time (180s) has elapsed. The timer starts counting following a compressor start. Stop command is ignored. Only a coast (inverse) command can override the time and stop the compressor.	180 sec	12sec
5.12	Terminal 27 Digital input	Designated for the LP switch.	[2]* Coast inverse	Stop inverse

The diagram below demonstrates how the function works:

- (a) Start signal is given by the unit controller
- (b) Compressor started
- (c) Compressor stop requested by the unit controller
- (d) Stop command is ignored. Stop delay warning (W97).
- (e) Compressor stops when minimum run time (180s) has elapsed.
- (f) Start signal is given by the unit controller
- (g) Start command is ignored
- (h) Compressor starts after the timer interval between starts (300s) has elapsed.
- (i) Compressor Coast (stop) This command can override the time minimum run time and stop the compressor immediately.

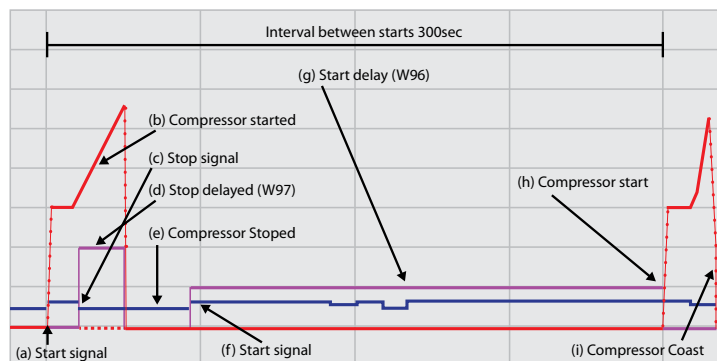

Note:
The short cycle protection function is not functional during Hand On control of the frequency converter via the LCP. If selecting Hand On or Off, the two timers will be reset to 0, and not start counting until Auto is pressed and an active start command applied. The counters are not available for display or monitoring.

Control logic

Defrost logic recommendations

In reversible systems, the defrost logic can be worked out to limit the effects of liquid flood back by:

1. Running at full load during defrost to share the liquid refrigerant between all the compressors.

2. Transferring the liquid refrigerant from one exchanger to the other thanks to pressures.

The following defrost logic combines both advantages:

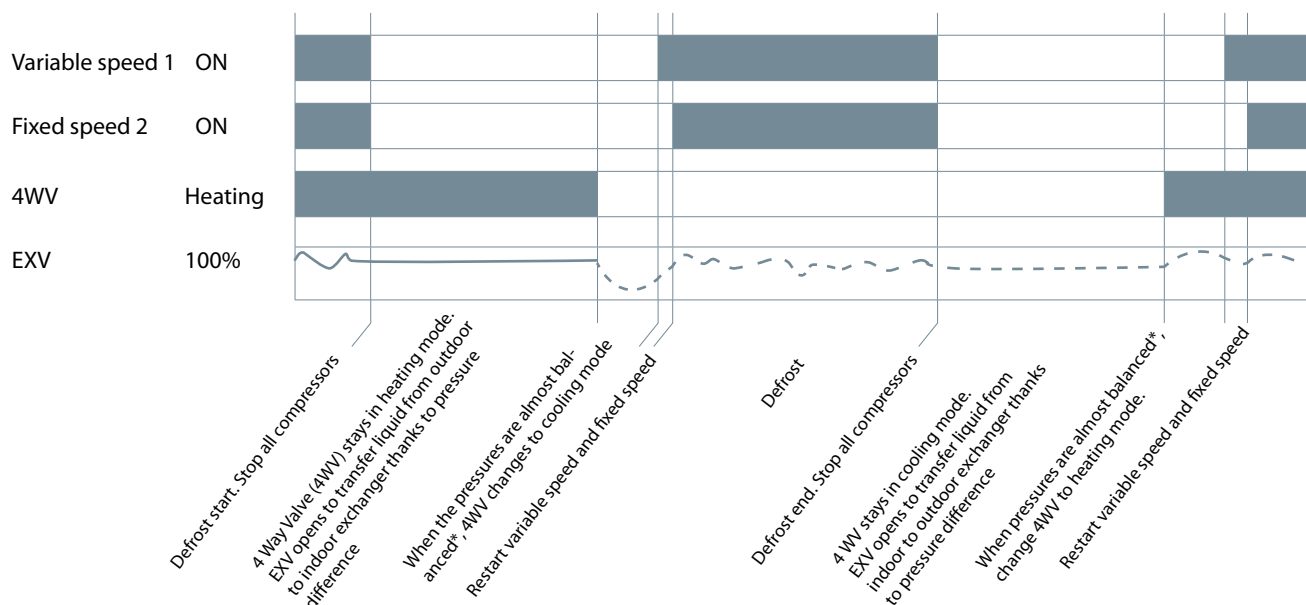

* EXV opening degree and time have to be set to keep a minimum pressure for 4 way valve moving.

Pump-down logic recommendations

Pump down is initiated prior to shutting down the last compressor on the circuit by de-energizing a liquid line solenoid valve or closing electronic expansion valve. When suction pressure reaches the cut-out pressure, the compressor is stopped.

Two types of pump-down exist:

- One-shot pump down (preferred): When the last compressor in the circuit stops, the suction pressure is falls by 1.5 bar below the nominal evaporating pressure with a minimum of 2,3 bar(g). Even if the suction pressure increases again, the compressor will not restart.
- Continuous pump-down: Compressor restarts automatically when the suction pressure increases.

The installation and service procedure for a parallel system are similar to basic single-system installations. The selection of additional system components for parallel installations follows the

basic system common rules. Please refer to the application guidelines for Danfoss VZH Gen3 scroll compressors (AB300034185311en) for detailed installation and service procedures.

Handling

Danfoss Commercial Compressors recommends using the lift and handling devices as shown on the right, and that the following procedure be used to prevent damage:

- There are two lifting rings on each compressor. Use all four rings.
- Maximum loads authorized per sling and for the hoist hook must not be lower than the weight of the assembly.
- If the tandem unit is already installed as a complete installation, it must never be lifted using the lifting rings on the compressors.

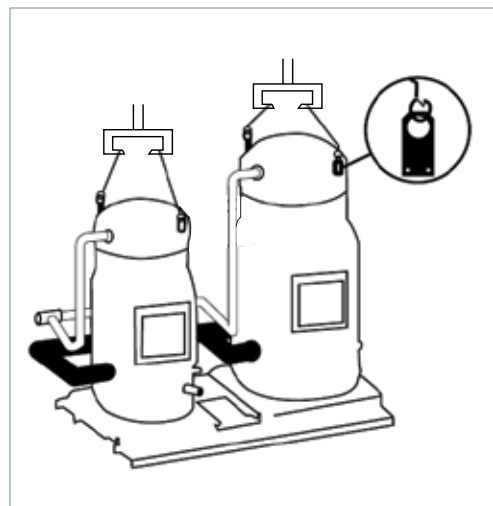

GENERAL INFORMATION

PRODUCT INFORMATION

SYSTEM DESIGN

ORDERING INFORMATION

Ordering information

To build a complete tandem installation, the customer must order two must order 2

compressors, one suction separator and one tandem accessory kit.

Compressor ordering codes

Danfoss VZH and DSH scroll compressors can be ordered in either industrial packs or in single packs. Please refer to the single compressor

application guideline for compressor ordering information (AB300034185311en for VZH Gen3, AB288965961751en for DSH).

Accessory ordering codes

The suction separator and tandem kit can be ordered using the code numbers listed in the table below. The suction separator and

the tandem kit selection should be based on compressor model, frequency of fixed speed compressor and oil level switch voltage.

Tandem model	Variable speed compressor	Fixed speed compressor	Suction direction	Suction separator			Tandem accessory kit		
				Hz (FS compressor)	Code	Pack size	Voltage of oil level switch	Code	Pack size
VZH178H	VZH088	DSH090	Left/Right	50 Hz	120Z0676	1	24V	120Z0653	1
							230V	120Z0654	1
				60 Hz	120Z0675	1	24V	120Z0653	1
							230V	120Z0654	1
VZH208H	VZH088	DSH120	Left/Right	50 Hz	120Z0664	1	24V	120Z0651	1
							230V	120Z0652	1
				60 Hz	120Z0658	1	24V	120Z0651	1
							230V	120Z0652	1
VZH257H	VZH117	DSH140	Left/Right	50 Hz	120Z0666	1	24V	120Z0653	1
							230V	120Z0654	1
				60 Hz	120Z0665	1	24V	120Z0653	1
							230V	120Z0654	1
VZH278H	VZH117	DSH161	Left/Right	50 Hz	120Z0665	1	24V	120Z0653	1
							230V	120Z0654	1
				60 Hz	120Z0674	1	24V	120Z0653	1
							230V	120Z0654	1
VZH301H	VZH117	DSH184	Left/Right	50 Hz	120Z0656	1	24V	120Z0651	1
							230V	120Z0652	1
				60 Hz	120Z0656	1	24V	120Z0651	1
							230V	120Z0652	1
VZH354H	VZH170	DSH184	Left	50 Hz	120Z0683	1	24V	120Z0682	1
							230V	120Z0681	1
				60 Hz	120Z0655	1	24V	120Z0682	1
			230V				120Z0681	1	
			Right	50 Hz	120Z0687	1	24V	120Z0682	1
							230V	120Z0681	1
60 Hz	120Z0687	1		24V	120Z0682	1			
			230V	120Z0681	1				
VZH410H	VZH170	DSH240	Left/Right	50 Hz	120Z0657	1	24V	120Z0649	1
							230V	120Z0650	1
				60 Hz	120Z0657	1	24V	120Z0649	1
							230V	120Z0650	1
VZH465H	VZH170	DSH295	Left/Right	50 Hz	120Z0655	1	24V	120Z0649	1
							230V	120Z0650	1
				60 Hz	120Z0655	1	24V	120Z0649	1
							230V	120Z0650	1

Accessories

Suction separator



Code no.	Description	Application	Packaging	Pack size
120Z0655	Hybrid manifold suction separator	VZH465H-50/60Hz right/left suction VZH354H-60Hz left suction	Single pack	1
120Z0657	Hybrid manifold suction separator	VZH410H-50/60Hz right/left suction	Single pack	1
120Z0656	Hybrid manifold suction separator	VZH301H-50/60Hz right/left suction	Single pack	1
120Z0666	Hybrid manifold suction separator	VZH257H-50Hz right/left suction	Single pack	1
120Z0665	Hybrid manifold suction separator	VZH257H-60Hz VZH278H-50Hz right/left suction	Single pack	1
120Z0658	Hybrid manifold suction separator	VZH208H-60Hz right/left suction	Single pack	1
120Z0664	Hybrid manifold suction separator	VZH208H-50Hz right/left suction	Single pack	1
120Z0674	Hybrid manifold suction separator	VZH278H-60Hz right/left suction	Single pack	1
120Z0675	Hybrid manifold suction separator	VZH178H-60Hz right/left suction	Single pack	1
120Z0676	Hybrid manifold suction separator	VZH178H-50Hz right/left suction	Single pack	1
120Z0683	Hybrid manifold suction separator	VZH354H-50Hz left suction	Single pack	1
120Z0687	Hybrid manifold suction separator	VZH354H-50/60Hz right suction	Single pack	1

Tandem accessory kit



Code no.	Description	Application	Packaging	Pack size
120Z0653	Oil level sensor 24V AC/DC, sleeves, gaskets	VZH178H-257H-278H with 24V oil level sensor	Single pack	1
120Z0654	Oil level sensor 230V AC, sleeves, gaskets	VZH178H-257H-278H with 230V oil level sensor	Single pack	1
120Z0651	Oil level sensor 24V AC/DC, sleeves, gaskets	VZH208H-301H with 24V oil level sensor	Single pack	1
120Z0652	Oil level sensor 230V AC/DC, sleeves, gaskets	VZH208H-301H with 230V oil level sensor	Single pack	1
120Z0649	Oil level sensor 24V AC/DC, sleeves, gaskets, grommets, washers, bolts	VZ410H-465H with 24V oil level sensor	Single pack	1
120Z0650	Oil level sensor 230V AC, sleeves, gaskets, grommets, washers, bolts	VZ410H-465H with 230V oil level sensor	Single pack	1
120Z0681	Oil level sensor 230V AC, sleeves, gaskets, grommets, washers, bolts	VZH354H with 230V oil level sensor	Single pack	1
120Z0682	Oil level sensor 24V AC, sleeves, gaskets, grommets, washers, bolts	VZH354H with 24V oil level sensor	Single pack	1

Oil level sensor



Code no.	Description	Application	Packaging	Pack size
120Z0561	Oil level sensor 24V AC/DC	VZH088-117-170 manifolding version	Single pack	1
120Z0562	Oil level sensor 230V AC	VZH088-117-170 manifolding version	Single pack	1

Accessories

Surface Sump Heater



Code no.	Description	Application	Packaging	Pack size	
120Z0388	Surface sump heater, 80W, 24V, CE, UL	VZH088-117	Multipack	8	
120Z0389	Surface sump heater, 80W, 230V, CE, UL		Multipack	8	
120Z0390	Surface sump heater, 80W, 400V, CE, UL		Multipack	8	
120Z0391	Surface sump heater, 80W, 460V, CE, UL		Multipack	8	
120Z0402	Surface sump heater, 80W, 575V, CE, UL		Multipack	8	
120Z0360	Surface sump heater + bottom insulation, 56 W, 24 V, CE, UL		VZH170	Multipack	6
120Z0376	Surface sump heater + bottom insulation, 56 W, 230 V, CE, UL	Multipack		6	
120Z0377	Surface sump heater + bottom insulation, 56 W, 400 V, CE, UL	Multipack		6	
120Z0378	Surface sump heater + bottom insulation, 56 W, 460 V, CE, UL	Multipack		6	
120Z0379	Surface sump heater + bottom insulation, 56 W, 575 V, CE, UL	Multipack		6	
120Z0667	48W 24V surface sump heater CE and UL	DSH090 to 184		Single pack	1
120Z0668	48W 230V surface sump heater CE and UL		Single pack	1	
120Z0669	48W 400V surface sump heater CE and UL		Single pack	1	
120Z0670	48W 460V surface sump heater CE and UL		Single pack	1	
120Z0671	48W 575V surface sump heater CE and UL		Single pack	1	
120Z0388	80W 24V surface sump heater CE and UL		Multipack	8	
120Z0389	80W 230V surface sump heater CE and UL		Multipack	8	
120Z0390	80W 400V surface sump heater CE and UL		Multipack	8	
120Z0391	80W 460V surface sump heater CE and UL		Multipack	8	
120Z0402	80W 575V surface sump heater CE and UL		Multipack	8	
120Z0703	56W 24V surface sump heater + bottom insulation, CE & UL		DSH240-295-381-485	Multipack	6
120Z0704	56W 230V surface sump heater + bottom insulation, CE & UL		DSH240-295-381-485	Multipack	6
120Z0705	56W 400V surface sump heater + bottom insulation, CE & UL		DSH240-295-381-485	Multipack	6
120Z0706	56W 460V surface sump heater + bottom insulation, CE & UL		DSH240-295-381-485	Multipack	6
120Z0707	56W 575V surface sump heater + bottom insulation, CE & UL		DSH240-295-381-485	Multipack	6

Model	Configuration	NRV code	
VZH178H	VZH088 + DSH090	VZH088	DSH090
		NRV16 (020B1059)	-
VZH208H	VZH088 + DSH120	VZH088	DSH120
		NRV16 (020B1059)	-
VZH257H	VZH117 + DSH140	VZH117	DSH140
		NRV19(020B1054)	-
VZH278H	VZH117 + DSH161	VZH117	DSH161
		NRV19(020B1054)	-
VZH301H	VZH117 + DSH184	VZH117	DSH184
		NRV19(020B1054)	-
VZH354H	VZH170 + DSH184	VZH170	DSH184
		NRV22 (020-1060)	-
VZH410H	VZH170 + DSH240	VZH170	DSH240
		NRV22 (020-1060)	-
VZH465H	VZH170 + DSH295	VZH170	DSH295
		NRV22 (020-1060)	-

GENERAL INFORMATION

PRODUCT INFORMATION

SYSTEM DESIGN

ORDERING INFORMATION

Oil Management logic

1. Oil management for hybrid manifolding system

An oil level sensor needs to be installed on the variable speed compressor. The oil level is permanently monitored by OEM main controller. When oil level is below the minimal, OEM

controller enters in oil management mode to recover a proper oil level in compressor. If oil level cannot be recovered, controller stops the system.

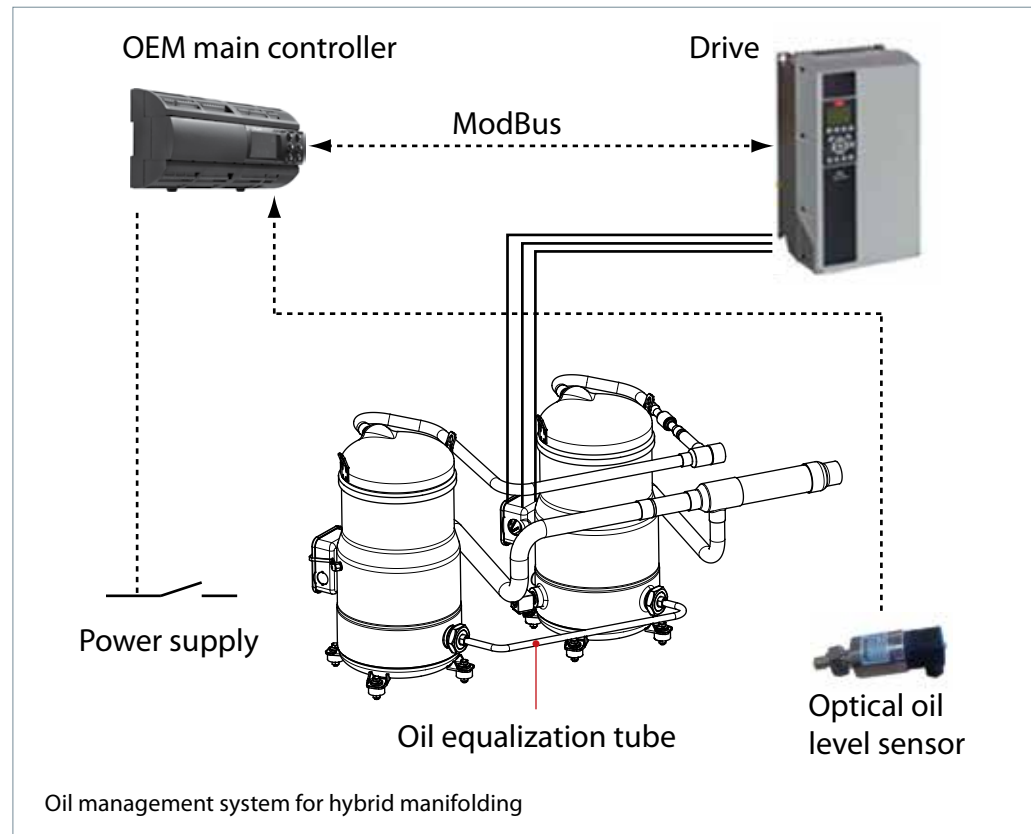

2. Oil management description

2.1 Basic rules

This specification describes the control logic to implement in OEM controller. This control logic must be implemented and thoroughly tested by OEM.

The variable speed compressor (VS) is primary and the fixed speed compressor (FS) is Secondary. FS must not run alone.

As oil balancing logic needs to start / stop compressor as well as increase / decrease speed, make sure expansion device is fast enough to maintain liquid flood back within acceptable limit during those transients (Manage super heat chapter).

2.2 Oil management modes The oil management control logic must include 3 steps.

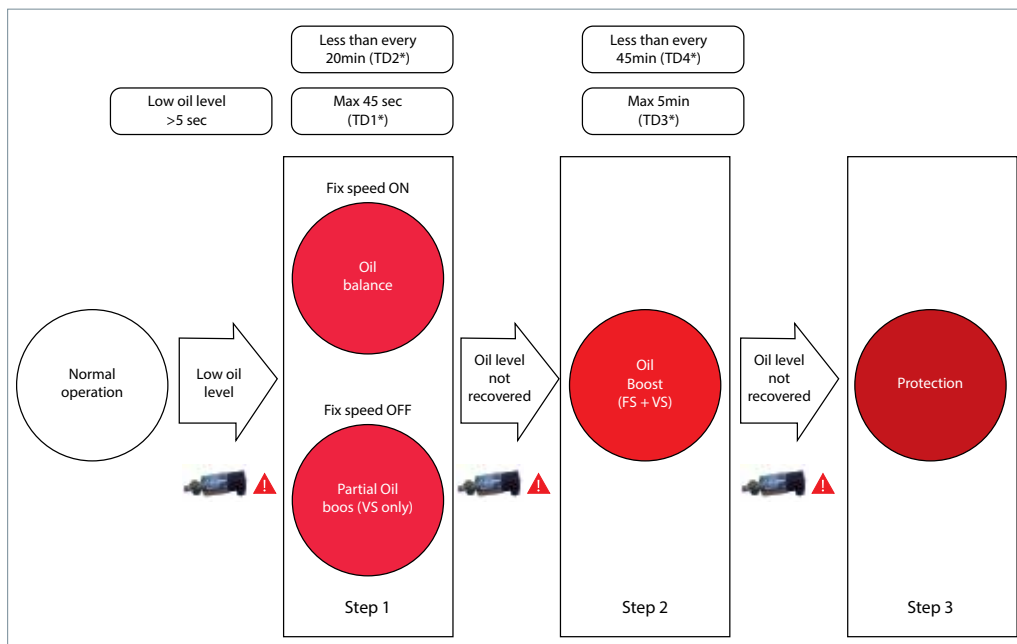

Step 1 (Oil balance or partial oil boost)

In case of low oil level detection by Oil level sensor on VS, there is 2 possible actions according to fix speed state:

- Fix speed is ON: Oil can be trapped in fix speed compressor due to pressure unbalance. Oil balance mode is activated. FS is stopped and VS speed is increased; pressure in VS become lower than FS oil is coming back through oil equalization line.
- Fix speed is OFF: Oil is trapped in the system. Partial oil boost is activated. VS speed is increased to slightly increase refrigerant velocity in the system and recover oil, FS remain OFF

TD1 is the maximum time to complete Step 1: If oil is not recovered within TD1, switch to Step 2: If oil is recovered within TD1 come back to normal operation. TD2 is the minimum interval between two step 1. If step 1 is requested in less

than TD2 after last step 1, switch immediately to step 2.

Step 2 (Full oil boost)

If oil level cannot be recovered within defined time, oil is trapped in the system. Full oil boost is activated. (VS speed is increased and fix starts (if not already ON). It considerably increases refrigerant velocity in the system and recovers oil.

TD3 is the maximum time to complete step 2. If oil is not recovered within TD3 switch to step 3. If oil is recovered within TD3 come back to normal operation. TD4 is the minimum interval between two step 2. In case of low oil level detection within a time <TD4, switch to step 3.

Step 3 (Protection)

If oil is still lower than limit after completed step 1 & 2, or if oil level drop within a time <TD4, controller must enter in protection mode, and stop the system in alarm.

Note: TD time is adjustable. Please refer to "Parameter and variable table" in page 31.

2.3 Steps description

2.3.1 Oil balance

Function description

Balance oil from FS compressor to VS Compressor.

Enter condition

Low oil level in VS compressor detected by oil level sensor.

AND

FS compressor is ON

AND

$t2 > TD2$, Interval between two Oil balance / Oil boost is $> TD2$

Cancel condition

High oil level in VS compressor detected by oil level sensor.

OR

$t1 > TD1$, Oil balance duration exceed TD1

Control sequence

1. At the initial state, VS and FS compressor are ON.
2. Low oil level detected in VS compressor. Reset and Start $t1$.
3. FS compressor must stop. VS compressor speed must increase to Fboost.
4. When high oil level detected in VS compressor.
 - VS compressor speed must be decreased to minimal speed Fmin.
 - Reset and Start $t2$
 - Reset $t1$
5. When VS compressor speed reaches Fstart, FS compressor must restart.

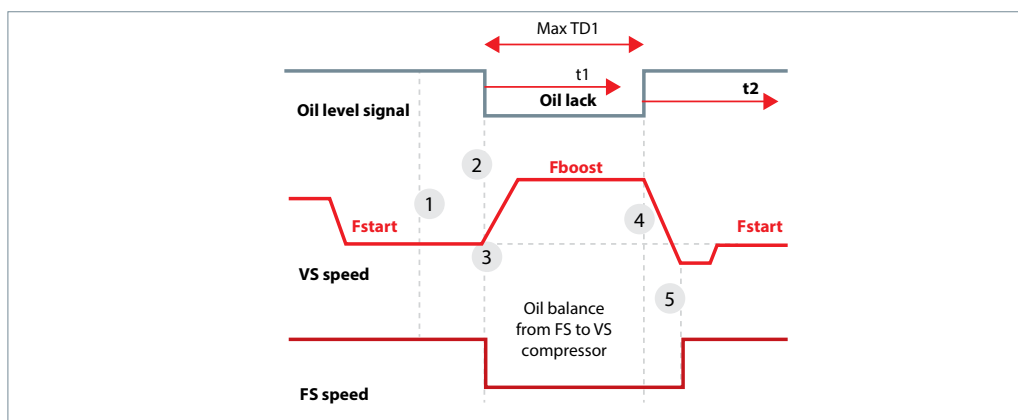

2.3.2 Partial oil boost

Function description

Return oil trapped in the system to compressors by increasing refrigerant mass-flow in the system.

Enter condition

Low oil level in VS compressor detected by oil level sensor.

AND

FS compressor is OFF

AND

$t_2 > TD_2$, Interval between two Oil balance / Oil boost is $> TD_2$

Cancel condition

High oil level in VS compressor detected by oil level sensor.

OR

$t_1 > TD_1$, Partial oil Boost duration exceed TD_1

Control sequence

- 1 At the initial state, VS compressor is ON and FS compressor is OFF.
- 2 Low oil level detected in VS compressor. Reset and start t_1
- 3 VS compressor speed must increase to F_{boost} .
- 4 When high oil level detected in VS compressor
 - VS compressor speed must be decreased to the initial speed (F_{start})
 - Reset and start t_2
 - Reset t_1

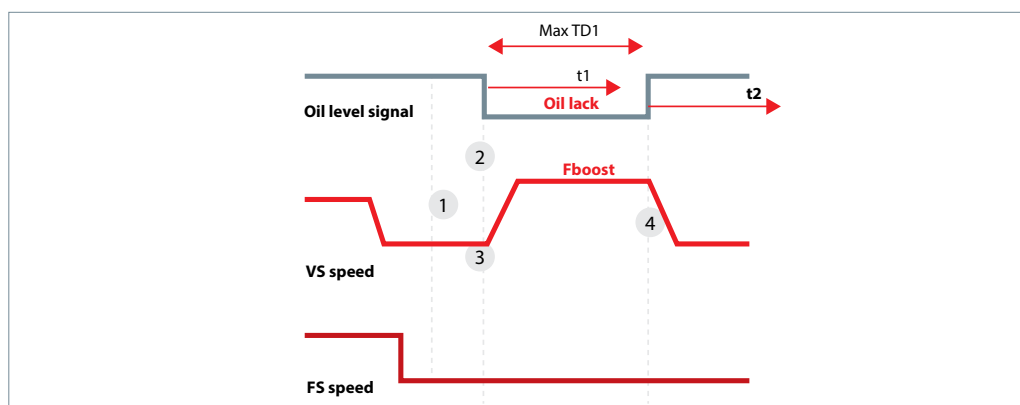

2.3.3 Oil boost

Function description

Return oil trapped in the system to compressors by increasing refrigerant mass-flow in the system.

Enter condition

Low oil level in VS compressor detected by oil level sensor.

AND

($t_1 > TD1$, Oil balance / boost duration $t_1 > TD1$ OR $t_2 < TD2$, Interval between two Oil balance / Oil boost is $< TD2$)

Cancel condition

High oil level in VS compressor detected by oil level sensor.

OR

$t_1 > TD3$, Oil balance / boost duration exceeds Maximum Oil boost duration

Control sequence

1. At initial state, oil level is low .Partial oil boost /Oil balance was not successful or was aborted because minim interval criteria. VS compressor is at Fstart and FS compressor is either ON or OFF.
2. VS compressor speed must increase to Fboost, FS compressor must start if not already ON
Reset and start t1
3. When High oil level detected in VS compressor.
 - VS compressor speed must be decreased to the initial speed (Fstart)
 - FS compressor to initial state.
 - Reset and start t2
 - Reset and start t3
 - Reset t1
4. When VS compressor speed reaches Fstart, FS compressor must restart (if was ON before)

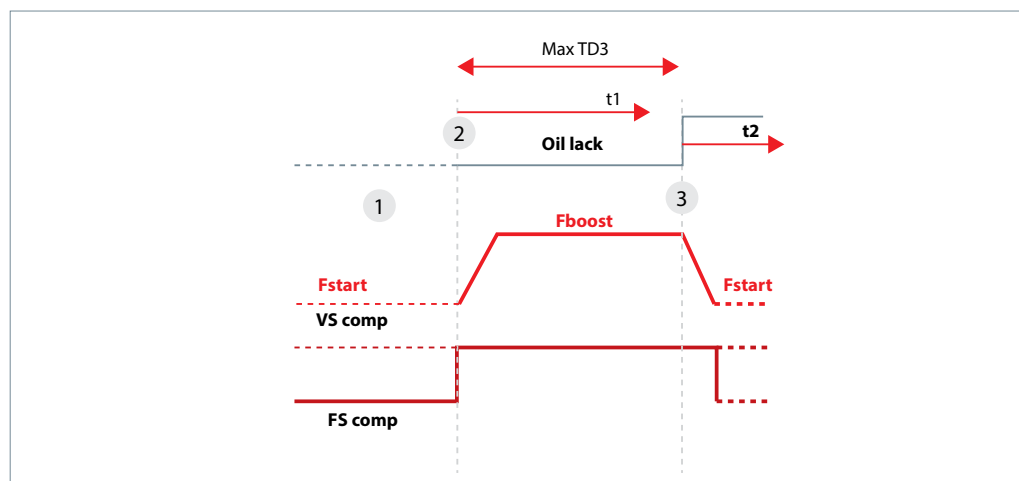

Annex

2.3.4 Protection

Function description

Stop compressors to prevent short of oil running.

Cancel condition

Manual Reset

Enter condition

Low oil level in VS compressor detected by oil level sensor.

AND

($t1 > TD3$, Oil balance / boost duration exceeds TD3 OR $t3 < TD4$, Interval between two Oil boost is $< TD4$)

Control sequence

Stop FS and VS compressor

Reset t1

Reset t2

Reset t3

2.4 Parameter and variable table

Name	Text	Attribute	Range	Default	Unit
Fboost	Boost action frequency	parameter	25~100	70	Hz
TD1	Maximum oil balance / Partial oil boost duration	parameter	10~240	30	second
TD2	Interval minimum between two oil balance / Partial oil boost	parameter	10~60	20	minutes
TD3	Maximum boost duration	parameter	5~12	5	minutes
TD4	Interval minimum between two oil boost	parameter	45~120	45	minutes
t1	Oil balance/ Partial oil boost timer	Variable			second
t2	Interval between two oil balance / Partial oil boost	Variable			minutes
t3	Interval between two oil boost	Variable			minutes

2.5 Sensor Wiring diagram

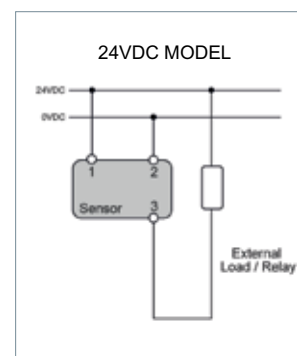
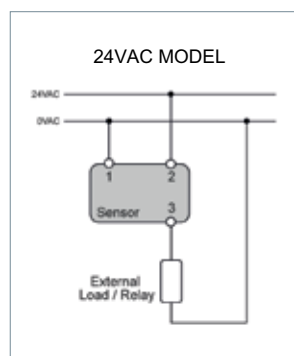
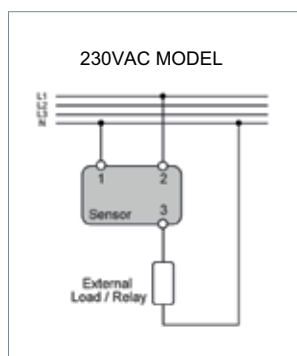

An TEKLAB LC-XN optical-electrical level sensor is fixed on the inverter compressor. The oil level sensor monitors the compressor oil level and sends oil level signal to an external relay (provided by OEM). Regarding this oil level signal, a 5 ± 2 seconds delay is recommended to be used to consider the oil level fluctuation which may trigger false alarms.

- Lack of oil: Circuit between 2 and 3 will be opened internally, there will be no current

flowing through load or coil of external relay. For relay, output is open.

- Enough oil: Circuit between 2 and 3 will be closed internally, there will be current flowing through load or coil of external relay. For relay, output is closed

For customers who needs UL certificates, please order 24V AC/DC sensor.

Danfoss Commercial Compressors

is a worldwide manufacturer of compressors and condensing units for refrigeration and HVAC applications. With a wide range of high quality and innovative products we help your company to find the best possible energy efficient solution that respects the environment and reduces total life cycle costs.

We have 40 years of experience within the development of hermetic compressors which has brought us amongst the global leaders in our business, and positioned us as distinct variable speed technology specialists. Today we operate from engineering and manufacturing facilities spanning across three continents.



Danfoss Scrolls



Danfoss Inverter Scrolls



Danfoss Turbocor Compressors



Danfoss Light Commercial Refrigeration Compressors



Danfoss Maneurop Reciprocating Compressors



Danfoss Optyma Condensing Units

Our products can be found in a variety of applications such as rooftops, chillers, residential air conditioners, heatpumps, coldrooms, supermarkets, milk tank cooling and industrial cooling processes.

<http://cc.danfoss.com>

Danfoss Commercial Compressors, BP 331, 01603 Trévoux Cedex, France | +334 74 00 28 29



Danfoss can accept no responsibility for possible errors in catalogues, brochures and other printed material. Danfoss reserves the right to alter its products without notice. This also applies to products already on order provided that such alterations can be made without subsequential changes being necessary in specifications already agreed. All trademarks in this material are property of the respective companies. Danfoss and the Danfoss logotype are trademarks of Danfoss A/S. All rights reserved.